

Sample NO: SY-TY-2022

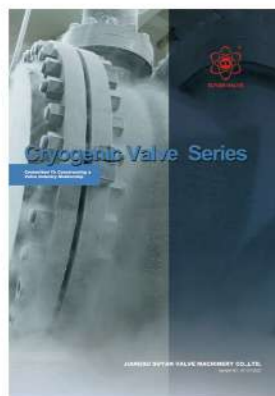

Sample NO: SY-CV-2022



Sample NO: SY-BV-2022

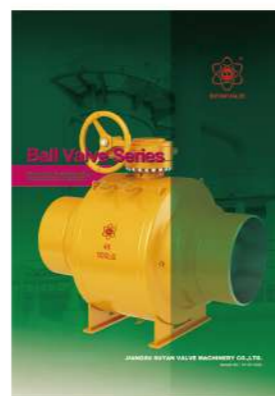

Sample NO: SY-CF-2022

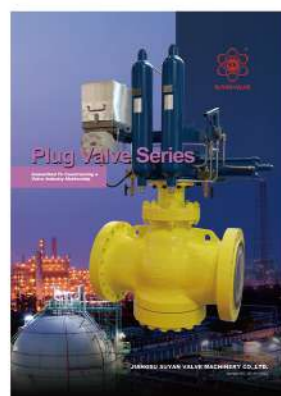

Sample NO: SY-PV-2022



Sample NO: SY-JKZZ-2016



Gate, Globe & Check Valve Series

Committed To Constructing a Valve Industry Mothership

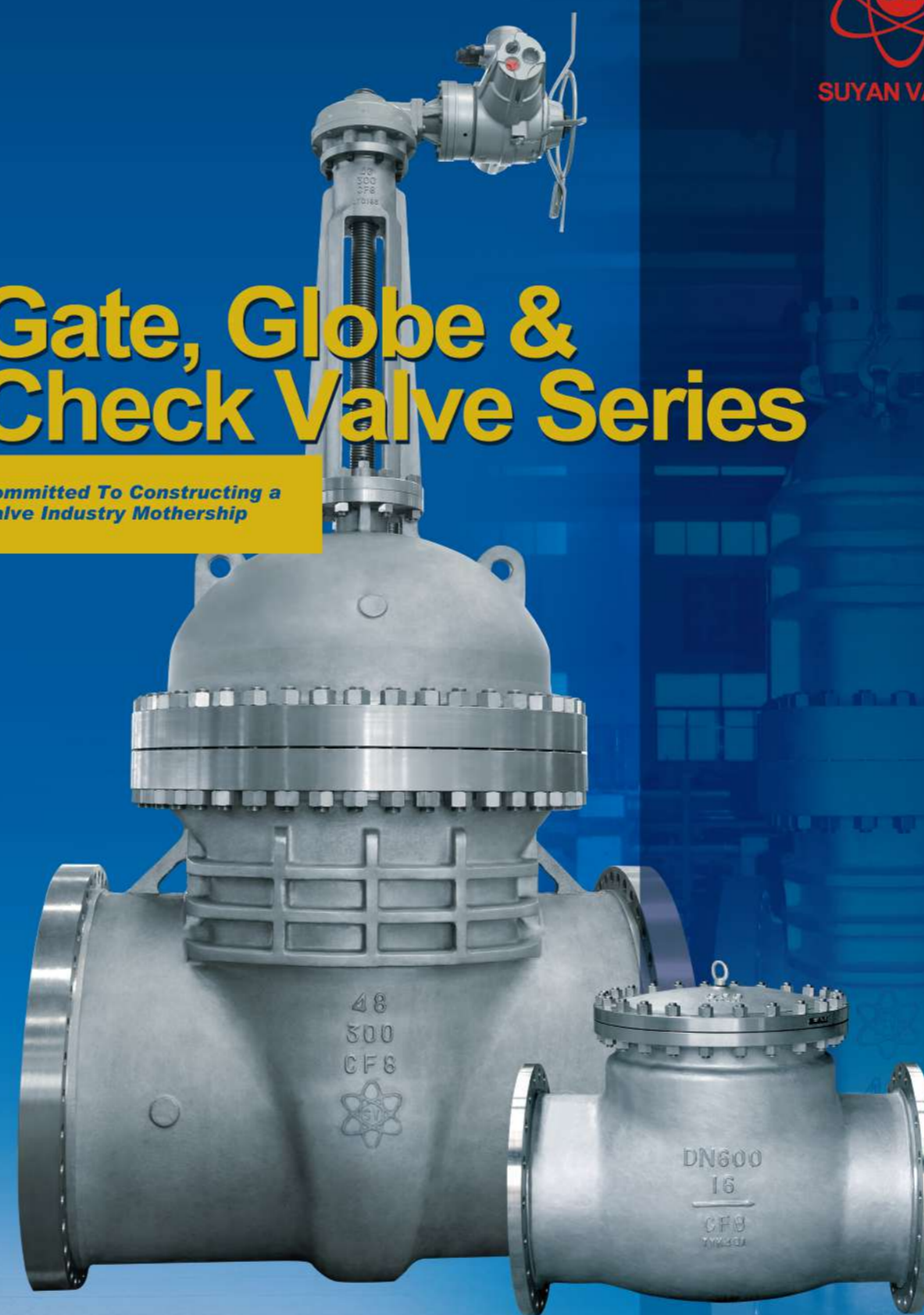

JIANGSU SUYAN VALVE MACHINERY CO.,LTD.

ADD: No. 28, Century Avenue, North District, Binhai County Industrial Park,
Yancheng City, Jiangsu Province
TEL: 0515-84194555 FAX: 0515-84199808 E-mail:hai977@126.com

www.suyangroup.com

JIANGSU SUYAN VALVE MACHINERY CO.,LTD.

Sample NO.: SY-TY-2022

SUYAN VALVE



Chairman: Mr. Zhenghai Han
Delegates in Jiangsu People's Congress
Party Representative in Jiangsu Province
Jiangsu Model Worker
Vice-Chairman of China General Machinery Industry Association
Executive Vice president of Jiangsu Valve Industry Association
President of Yancheng Petroleum Machinery Industry Association
Committee Member of National Valve Standardization Technical Committee

Comprehensive Fluid Control Solutions

CONTENT



DIRECTORY

Company Profile	01
Quality Assurance	03
Cast&forged Workshop	05
Data Management	07
Production Equipment	09
Gate Valve	13
Globe Valve	15
Valued Customers	17
How To Order	19
Cast Steel Gate Valve Ga Series	20
Ga Series	21
Through Conduit Slab Gate Valve	26
Through Conduit Expanding Gate Valve	31
Forged Steel Gate Valve	36
Globe Valve G1 Series	38
Forged Steel Globe Valve	45
Swing Gheck Valve Sc/sn Series	48
Dual Plate Check Valve Sdp Series	54
Forged Steel Check Valve	61
Cast Steel Pressure Seal Valve	67
Memo	84

COMPANY PROFILE



The Registered Capital is 310 million RMB,
Total assets of 5 billion RMB,
Covering an area of 80 hectares,
The building area is 320,000 square meters,
Existing staff of 1300 people.



National High-Tech Enterprise,
National Special "Little Giant" Enterprise
National Postdoctoral Research Station,
National Intellectual Property Advantage Enterprise
Provincial Enterprise Technology Center,
Provincial Engineering Research Center
Provincial Graduate Workstation
Jiangsu boutique Enterprise
Qualified Supplier of CNNC

More than 1,000 sets of sophisticated
manufacturing equipment
520 sets of testing equipment
Set up a national laboratory

Developed more than 300 new products
65 national invention patents
310 utility model patents
Participated in the drafting and revision of 43 standards

since 1991



The sales market covers
China End Users PetroChina,
Sinopec, CNOOC and global customers.
Provide fast after-sales service,
distributed all over the country
and around the world.



QUALITY ASSURANCE



Detection test project is complete

SUYAN sequent imported production line such as most advanced digital control workstation, touchable induction three-coordinate digital instrument (made in USA), portable spectrum analyzer, ultra-low temperature detecting system, vacuum & micro-leakage detecting system and NDT instrument including ultrasonic detector etc. the advanced equipment and professional QC inspector jointly guarantee the high quality of product.



CAST&FORGED WORKSHOP



As one of the pressure-bearing equipment for fluid control pipelines, the quality of valve body is the most important for the life and personnel environmental safety, especially in the conditions of high temperature and pressure. Therefore, valves are always critical. The customer needs to pre-quality the first certified material before approving the valve manufacturer as a cooperative supplier.



Casting production line

Coated sand production line



DATA MANAGEMENT



Automatic
Production
Line



MES
Management
System



The advanced hard facilities ensure
SUYAN to be at best position during
market competition.



PRODUCTION EQUIPMENT

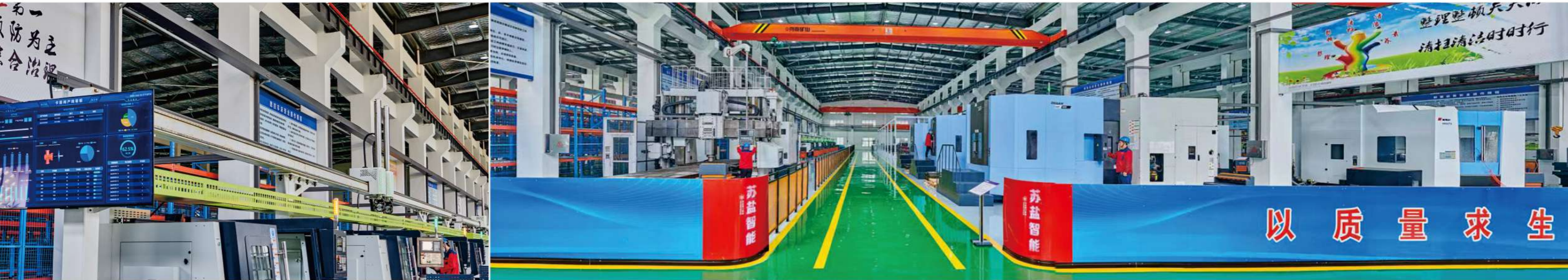

SUYAN is fitted with precise numerical control machine tools and processing center, advanced equipment testing instruments, superior technology, consummate quality control system, professional elite and outstanding scientific research team. We fully use technology, new workmanship and new materials to ensure the dependability of products.



MACHINING CENTER



PRODUCTION EQUIPMENT



Fully CNC Automation

Fully CNC, automatic production process to bring high precision, high quality stable and reliable products High-tech equipment, professional team, to ensure excellent product quality



Committed to providing customers with quality products and services

SUYAN refinement of the accuracy of the pursuit of production. Constantly improve the lean production mode, including every parts, are strictly according to standard meticulously, ensure that the products of high quality.



GLOBE VALVE



From the blank casting to the final product, it has advanced inspection means and testing equipment for quality control. All products are subject to accurate material analysis and dimensional inspection according to relevant standards, strict process inspection is carried out throughout the production process, each valve is manufactured according to customer requirements or international standards, and final inspection is conducted before shipment. We will strive to achieve high quality valves.



Adhere to excellence,
create excellent quality



VALUED CUSTOMERS



 RESOURCES GAS	 TIANLI GAS	 PETROBRAS	 SINOPEC ENGINEERING
 WISON	 ENERGAS	 SHAANGU	 WISON
 XINHUA CHEMICAL	 FURUI SE	 CNMIC	 HGMRI
 TCC	 DATANG ENERGY	 CTCI	 مشرق ميتال
 BAYER	 LIAHERD	 CNWG	 ZJ UNIVERSITY

We Have Provided Matching Service For Many National And Foreign Stress Projects

Quality engineering long-lasting quality

Under many years brand operating and aborative exercising, the strength and credit of company are increasing steadily, at present Su Yan has been China petrification group material equipment company; China petrol & natural gas group company; China Aluminum Group company and the pointing member unit of China Sea Petroleum, metallurgy and steel-making, electricity system. SuYan brand series valves are sold to such over 10 countries and areas, welcomed by vast customers.

 SINOPEC	 CNPC	 SNPTC	 CNOOC	 SINOCHEN	 CHEMCHINA	
 CSSC	 CGDC	 CRECG	 CHALCO	 CHINA XD	 SHENHUA GROUP	 CHINAGAS
 CMCC	 SINOPHARM	 BAOSTEEL	 BAOGANG GROUP	 ANGANG STEEL	 SHOUGANG STEEL	 BEIJING GAS
 BEIJING GAS	 XINAO GAS	 TOWNGAS	 GUANGZHOU GAS	 SHANGHAI GAS	 XINJIANG GAS	 SHENYANG GAS





Example:

20	GA	1	R	G	WCB	8	NC
----	----	---	---	---	-----	---	----

20	VALVE SIZE									
	VALVE TYPE									
	Symbol	Valve type	Symbol	Valve type	Symbol	Valve type				
GA	GA	Gate	SC*	Swing Check	SDP	Dual Plate Check Valve	GLPS	Pressure Seal Globe Valve		
	GL	Golbe	SN*	Swing Check	GAPS	Pressure Seal Gate Valve	SCPS	Pressure Seal Swing Check Valve		
*SC:Out through Hinge Pin		*SC:Internal Hinge Pin								
1	VALVE CLASS									
	Class	150	300	600	900	1500	2500			
	Code	1	3	6	9	15	25			
R	END CONNECTIONS									
	Symbol	End	Symbol	End	Symbol	End	Symbol	End		
	R	Raised face flanged	B	Butt-weld	J	RTJ flanged	F	Flat face flanged	W	Wafer
G	OPERATOR									
	Symbol	Description	Symbol	Description	Symbol	Description				
	G	Gear operator	M	Electric actuator	BS	Bare Shaft				
WCB	BOOT MATERIALS									
	Body Materials	WCB	LCB	LCC	WC6	WC9	C5	C12		
	ASTM Ref	A216 Gr.WCB	A352 Gr.LCB	A352 Gr.LCC	A217 Gr.WC6	A217 Gr.WC9	A217 Gr.C5	A217 Gr.C12		
	Body Materials	CF8	CF8M	CF3	CF3M	CD4MCuN	4A			
ASTM Ref	A351 Gr.CF8	A351 Gr.CF8M	A351 Gr.CF3	A351 Gr.CF3M	A995 Gr.CD4MCuN	A890 GR.4A				
8	TRIM MATERIALS									
	API 600 Trim Number	Symbol	Disc Surface	Seat Surface	Stem Material					
	1	1	13Cr	13Cr	ASTM A 182 Grade F6a					
	2	2	304SS	304SS	ASTM A 182 Grade F304					
	5	5	Stellite.6	Stellite.6	ASTM A 182 Grade F6a					
	8	8	13Cr	Stellite.6	ASTM A 182 Grade F6a					
	9	9	Monel	Monel	Monel					
	10	10	316SS	316SS	ASTM A 182 Grade F316					
12	12	316SS	Stellite.6	ASTM A 182 Grade F316						
NC	SPECIAL CODE									
	Symbol	Description	Symbol	Description	Symbol	Description				
	NC	Nace	EB	Extended Bonnet	ES	Extended Stem				
	NRS	None Rising Stem	BP	By Pass	LE	Low Emission				



SUYAN GROUP

Cast Steel Gate Valve GA Series



SuYan series Gate Valve are manufactured in accordance with API 600, ASME B16.34 specification and tested to API 598, and this series valves are of API 591 certified, and API624, ISO15848, TA Luft Certified. To ensure casting integrity, all pressure contain casting are from SuYan own foundry.

GA Series

Design Features

- Flexible Wedge
- Optional Full Jacket or Semi-jacket Design
- Optional Stem Extension
- Optional Double Packing With Lantern Ring
- Optional Live Loaded Gland Flange
- Optional Bellow Seal

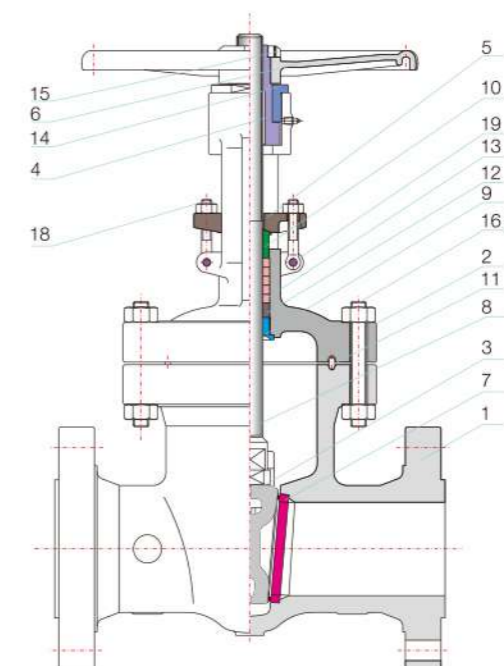

No.	Part	Standard	Stainless Steel	Low Temperature	High Temperature	Sour Service
1	Body	ASTM A216 WCB	ASTM A351 CF8M	ASTM A352 LCC	ASTM A217 WC9	ASTM A216 WCB
2	Bonnet	ASTM A216 WCB	ASTM A351 CF8M	ASTM A352 LCC	ASTM A217 WC9	ASTM A216 WCB
3	Wedge	ASTM A216 WCB+Cr13	ASTM A351 CF8M	ASTM A352 LCC+316	ASTM A217 WC9+STL.6	ASTM A216 WCB+Cr13
4	Stem Nut	ASTM A439 D-2	ASTM A439 D-2	ASTM A439 D-2	ASTM A439 D-2	ASTM A439 D-2
5	Gland Flange	ASTM A216 WCB	ASTM A351 CF8M	ASTM A352 LCC	ASTM A217 WC9	ASTM A216 WCB
6	Handwheel	Ductile Iron	Ductile Iron	Ductile Iron	Ductile Iron	Ductile Iron
7	Seat Ring	ASTM A105N+STL.6	ASTM A182 F316+STL.6	ASTM A350-LF2+STL.6	ASTM A182-F22+STL.6	ASTM A105N+STL.6
8	Stem	ASTM A182 F6a	ASTM A182 F316	ASTM A182 F316	ASTM A182 F6a	ASTM A182 F6a(NACE)
9	Back Seat	ASTM A276 410	ASTM A276 316	ASTM A276 316	ASTM A276 410	ASTM A276 410(NACE)
10	Gland	ASTM A276 410	ASTM A276 316	ASTM A276 316	ASTM A276 410	ASTM A276 410(NACE)
11	Gasket *	SPW SS+Graphite/RTJ.SS	SPW SS+Graphite/RTJ.SS	SPW SS+Graphite/RTJ.SS	SPW SS+Graphite/RTJ.SS	SPW SS+Graphite/RTJ.SS
12	Spacer Ring	ASTM A276 410	ASTM A276 316	ASTM A276 316	ASTM A276 410	ASTM A276 410
13	Packing	Graphite	Graphite	Graphite	Graphite	Graphite
14	Retaining Nut	Carbon Steel	Stainless Steel	Carbon Steel	Carbon Steel	Carbon Steel
15	Handwheel Nut	Carbon Steel	Stainless Steel	Carbon Steel	Carbon Steel	Carbon Steel
16	Bonnet Stud	ASTM A193 B7	ASTM A193 B8	ASTM A320 L7	ASTM A193 B16	ASTM A193 B7M
17	Bonnet Nut	ASTM A194 2H	ASTM A194 8	ASTM A194 7	ASTM A194 4	ASTM A194 2HM
18	Eye Bolt	ASTM A193 B7	ASTM A193 B8	ASTM A320 L7	ASTM A193 B16	ASTM A193 B7M
19	Eye Bolt Pin	Carbon Steel	Stainless Steel	Stainless Steel	Stainless Steel	Carbon Steel

* 150LB Reinforced SS+Graphite

GA SERIES GATE VALVE



SUYAN VALVE

150LB 300LB

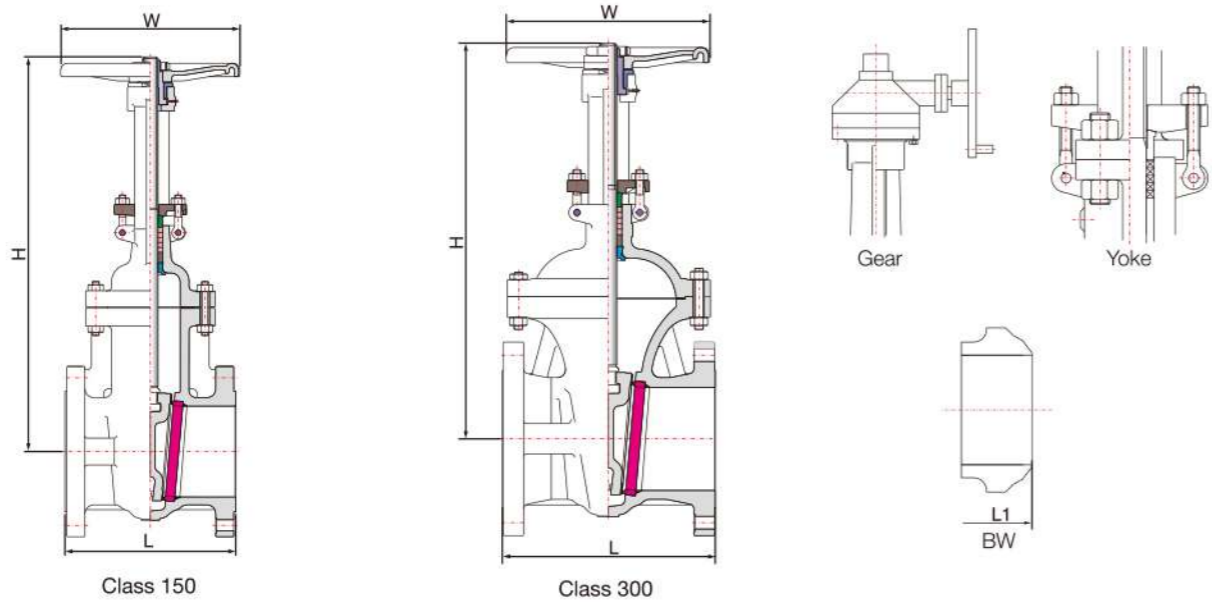

Class 150

NPS	in	2"	2-1/2"	3"	4"	5"	6"	8"	10"	12"	14"	16"	18"	20"	24"	26"	28"	30"	32"	36"	40"	42"	48"
DN	mm	50	65	80	100	125	150	200	250	300	350	400	450	500	600	650	700	750	800	900	1000	1050	1200
L(RF)	in	7	7.5	8	9	10	10.5	11.5	13	14	15	16	17	18	20	22	24	24	26	28	30	31	34
	mm	177.8	190.5	203.2	228.6	254	266.7	292.1	330.2	355.6	381	406.4	431.8	457.2	508	559	610	610	660	711.2	762	787.4	863.6
L1(BW)	in	8.5	9.5	11.1	12	15	15.9	16.5	18	19.8	22.5	24	26	28	32	34	36	36	38	40	42	43	46
	mm	215.9	241.3	282.4	304.8	381	403.4	419.1	457.2	501.7	571.5	609.6	660.4	711.2	812.8	864	914	914	965	1016	1067	1092	1168
W	in	7.9	7.9	9.8	9.8	13.8	13.8	13.8	15.7	17.7	19.7	22	25.2	26.8	28.3	24	24	24	*24	*43	*31.9	*31.9	*31.9
	mm	200	200	250	250	350	350	350	400	450	500	560	640	680	720	610	610	610	*610	*810	*810	*810	*810
H	in	12.8	14.5	16.5	19.2	22.2	23.9	29.6	35.0	42.0	45.8	51.7	56.7	63.5	73.7	92.9	110.4	110.4	140.7	108.5	169.7	178.2	197.2
	mm	325	368	420	487	565	608	751	890	1067	1163	1313	1441	1612	1872	2360	2805	2805	3574	3757	4311	4527	5010
WT(RF)	kg	19	26	35	49	64	81	127	204	291	400	486	610	788	1446	1570	1900	2540	2958	3380	4815	5300	7110
WT(BW)	kg	15	18	26	41	58	69	108	156	248	365	482	587	752	1405	1521	1838	2261	2490	3310	4840	5275	7050

Class 300

NPS	in	2"	2-1/2"	3"	4"	5"	6"	8"	10"	12"	14"	16"	18"	20"	24"	26"	28"	30"	32"	36"	40"	42"	48"
DN	mm	50	65	80	100	125	150	200	250	300	350	400	450	500	600	650	700	750	800	900	1000	1050	1200
L-L1 (RF-BW)	in	8.5	9.5	11.1	12	15	15.9	16.5	18	19.8	30	33	36	39	45	49	53	55	60	68	76	78	88
	mm	215.9	241.3	282.4	304.8	381	403.4	419.1	457.2	501.7	762	838.2	914.4	990.6	1143	1245	1346	1397	1524	1727	1930	1981	2235
W	in	7.9	9.8	9.8	9.8	13.8	13.8	15.7	17.7	19.7	22	25.2	26.8	29.9	29.9	*24	*24	*31.9	*31.9	*31.9	*39.4	*39.4	*39.4
	mm	200	250	250	250	350	350	400	450	500	560	640	680	760	760	*610	*610	*810	*810	*810	*1000	*1000	*1000
H	in	14.4	17.1	17.5	20.3	24.7	25.4	31.5	36.9	44.1	47.2	53.3	59.5	65.0	76.8	117.6	122.8	132.3	145.4	152.7	179	186.6	211.5
	mm	365	435	445	515	628	645	800	936	1120	1200	1355	1512	1650	1950	2986	3120	3361	3692	3879	4547	4739	5373
WT(RF)	kg	26	35	57	74	109	147	235	350	522	683	950	1145	1634	2660	3090	3312	3597	4850	6850	8460	9500	12400
WT(BW)	kg	17	26	48	65	90	113	164	344	475	565	805	1058	1412	2304	2540	2725	3057	4122	4990	6160	6800	9000

* Gear Operator

GA SERIES GATE VALVE



SUYAN VALVE

600LB 900LB

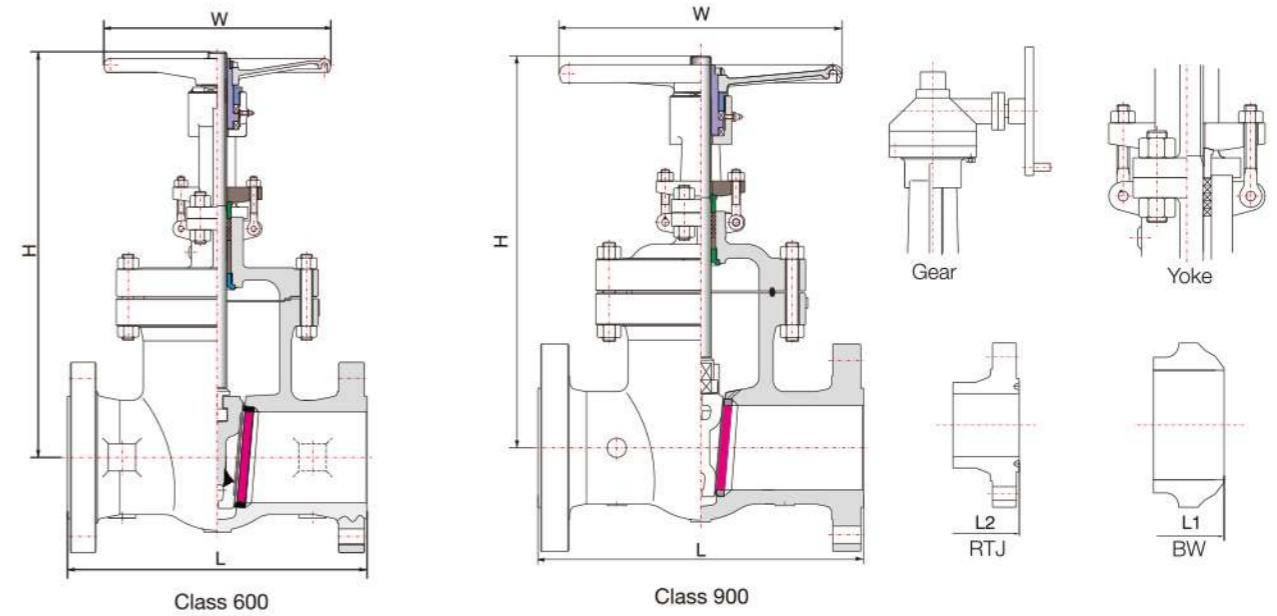

Class 600

NPS	in	2"	2-1/2"	3"	4"	5"	6"	8"	10"	12"	14"	16"	18"	20"	24"	26"	28"	30"	32"	36"	40"	42"	48"
DN	mm	50	65	80	100	125	150	200	250	300	350	400	450	500	600	650	700	750	800	900	1000	1050	1200
L-L1 (RF-BW)	in	11.5	13	14	17	20	22	26	31	33	35	39	43	47	55	57	61	65	70	82	90	96	100
	mm	292.1	330.2	355.6	431.8	508	558.8	660.4	787.4	838.2	889	990.6	1092.2	1193.8	1397	1448	1549	1651	1778	2082	2286	2438	2540
L2 (RTJ)	in	11.6	13.1	14.1	17.1	20.1	22.1	26.1	31.1	33.1	35.1	39.1	43.1	47.3	55.4	57.5	61.5	65.5	70.6	82.6			
	mm	295.3	333	358.7	435.2	511	562	663.4	790.5	841.2	892	993.6	1095.2	1200.2	1406.7	1461	1562	1664	1794	2098			
W	in	9.8	9.8	11.8	13.8	15.7	17.7	19.7	25.2	26.8	28.3	29.9	35.0	42.9	42.9	*31.9	*39.4	*39.4	*39.4	*39.4	*47.2	*47.2	*47.2
	mm	250	250	300	350	400	450	500	640	680	720	760	890	1090	1090	*810	*1000	*1000	*1000	*1000	*1200	*1200	*1200
H	in	14.0	17.4	18.8	21.7	30.3	29.0	35.2	39.9	44.7	51.5	54.9	59.7	66.7	76.3	124	132.4	139.7	150	167.7	183.9	193.7	231.3
	mm	356	442	478	552	700	737	894	1013	1136	1309	1395	1516	1693	1938	3150	3362	3549	3811	4260	4670	4921	5876
WT(RF)	kg	39	52	68	120	170	273	402	610	902	1245	1530	2030	2975	4252	5220	6050	6945	8312	10000	14300	16460	22900
WT(BW)	kg	28	42	55	84	125	204	337	548	905	974	1345	1730	2415	3415	4295	4980	5710	6834	8220	11755	13530	18820

Class 900

NPS	in	2"	2-1/2"	3"	4"	6"	8"	10"	12"	14"	16"	18"	20"	24"	26"	28"	30"	32"	36"
DN	mm	50	65	80	100	150	200	250	300	350	400	450	500	600	650	700	750	800	900
L-L1 (RF-BW)	in	14.5	16.5	15	18	24	29	33	38	40.5	44.5	48	52	61	65.5	70	74.5	78.9	87.9
	mm	368.3	419	381	457.2	609.6	736.6	838.2	965.2	1028.7	1130.3	1219.2	1321	1549.4	1664	1778	1892	2004	2232
L2(RTJ)	in	14.6	16.6	15.1	18.1	24.1	29.1	33.1	38.1	40.9	44.9	48.5	52.5	61.8					
	mm	371.6	422	384.2	460.5	612.9	740	841.2	968.2	1038.4	1140	1232	1333	1568.5					
W	in	9.8	11.8	13.8	15.7	22	25.2	26.8	29.9	29.9	*24	*31.9	*31.9	*31.9	*39.4	*39.4	*47.2	*47.2	*47.2
	mm	250	300	350	400	560	640	680	760	760	*610	*810	*810	*810	*1000	*1000	*1200	*1200	*1200
H	in	17.2	19	21	23.5	31	34.9	42.2	46.9	50.2	76	90.2	95.2	110.6	111.5	114.8	118.1	121.4	128
	mm	437	486	545	600	776	886	1071	1190	1275	1930	2290	2417	2808	2833	2916	3000	3083	3250
WT(RF)	kg	74	92	101	172	372	640	1100	1360	2250	2850	3870	4860	6100	7300	7600	9800	11950	15000
WT(BW)	kg	54	65	70	110	265	498	810	1228	2009	2563	3300	4050	6120	5500	6900	9000	11000	13500

* Gear Operator

GA SERIES GATE VALVE



SUYAN VALVE

1500LB 2500LB

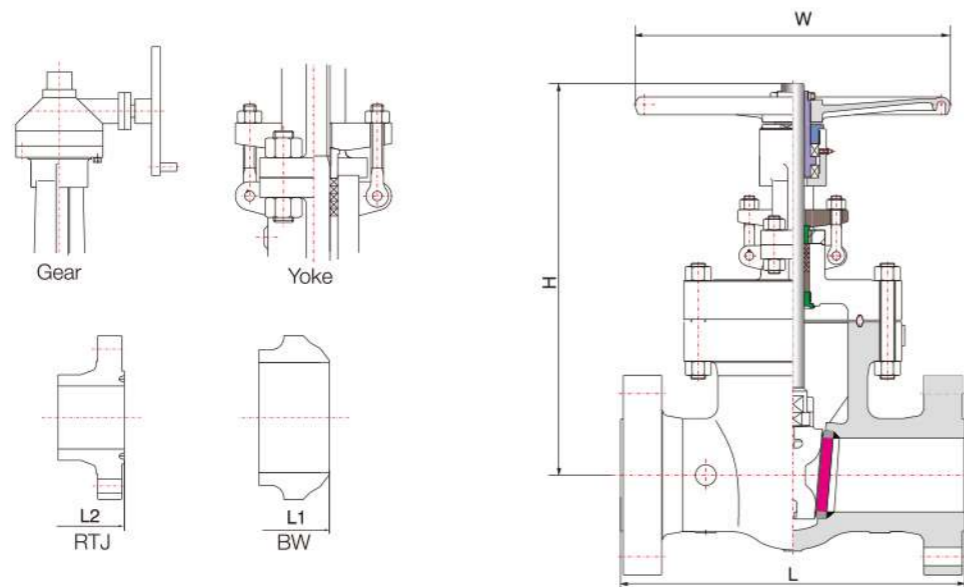

Class 1500

NPS	in	2"	2-1/2"	3"	4"	6"	8"	10"	12"	14"	16"	18"	20"	24"	26"	28"	30"
DN	mm	50	65	80	100	150	200	250	300	350	400	450	500	600	650	700	750
L-L1 (RF-BW)	in	14.5	16.5	18.5	21.5	27.8	32.8	39.0	44.5	49.5	54.5	60.5	65.5	76.5	82	87.5	93
	mm	368.3	419	469.9	546.1	704.9	831.9	990.6	1130.3	1257	1384	1537	1664	1943	2083	2222.5	2362
L2 (RTJ)	in	14.6	16.6	18.6	21.6	28.0	33.1	39.4	45.1	50.3	55.4	61.4	66.4	77.6			
	mm	371.6	422	473.2	549.4	711.2	841.5	1000	1146	1276	1407	1559	1686	1972			
W	in	11.8	11.8	15.7	19.7	25.2	29.9	*24	*24	*24	*24	*39.4	*39.4	*39.4	*47.2	*47.2	*47.2
	mm	300	300	400	500	640	760	*610	*610	*610	*610	*1000	*1000	*1000	*1200	*1200	*1200
H	in	17.2	21.2	22.5	24.4	32.3	37.3	56.7	62	70.8	77.3	110.7	121.2	140.6	151	158	168
	mm	437	538	572	621	821	947	1440	1575	1798	1963	2812	3078	3570	3836	4012	4268
WT(RF)	kg	74	131	165	248	510	1040	1910	2260	4100	6200	8100	11130	13300	16500	18700	20900
WT(BW)	kg	54	105	129	197	358	761	1640	1945	3200	5300	7100	10100	12900	15700	17500	19300

Class 2500

NPS	in	2"	2-1/2"	3"	4"	6"	8"	10"	12"	14"	16"	18"	20"	24"
DN	mm	50	65	80	100	150	200	250	300	350	400	450	500	600
L-L1 (RF-BW)	in	17.8	20	22.8	26.5	36	40.2	50	56	62	68	74	80	91.9
	mm	451	508	578	673	914	1022	1270	1422	1575	1727	1879	2031	2335
L2 (RTJ)	in	17.9	20.2	23	26.9	36.5	40.9	50.9	56.9					
	mm	454	514	584	683	927	1038	1445	1445					
W	in	13.8	17.7	17.7	19.7	24	*24	*24	*24	*31.9	*31.9	*31.9	*39.4	*39.4
	mm	350	450	450	500	610	*610	*610	*610	*810	*810	*810	*1000	*1000
H	in	20.7	22.2	22.9	34.3	43.1	50.9	65.0	71.1	76.6	88.6	100.6	112.6	136.6
	mm	527	563	582	870	1095	1295	1652	1806	1945	2250	2555	2860	3470
WT(RF)	kg	130	200	245	490	985	1600	4570	6100	8120	10170	12100	14700	16500
WT(BW)	kg	95	150	175	375	765	1310	3800	5200	7510	9730	10900	12100	14700

* Gear Operator



SUYAN VALVE

SUYAN GROUP

Through Conduit Slab Gate Valve



Seats-Soft & Metal

In the event of soft seat damage, the seating of metal to metal will function as a secondary seal.

Double Block

When the valve is in the closed position and also has equal or no pressure, both spring loaded seats can shut off line pressure independently of upstream and downstream pressure. Self Relieving Cavity

Through Conduit Slab Gate Valve are manufactured in accordance with API 6D.

SLAB GATE VALVE

Expanded View



SUYAN VALVE

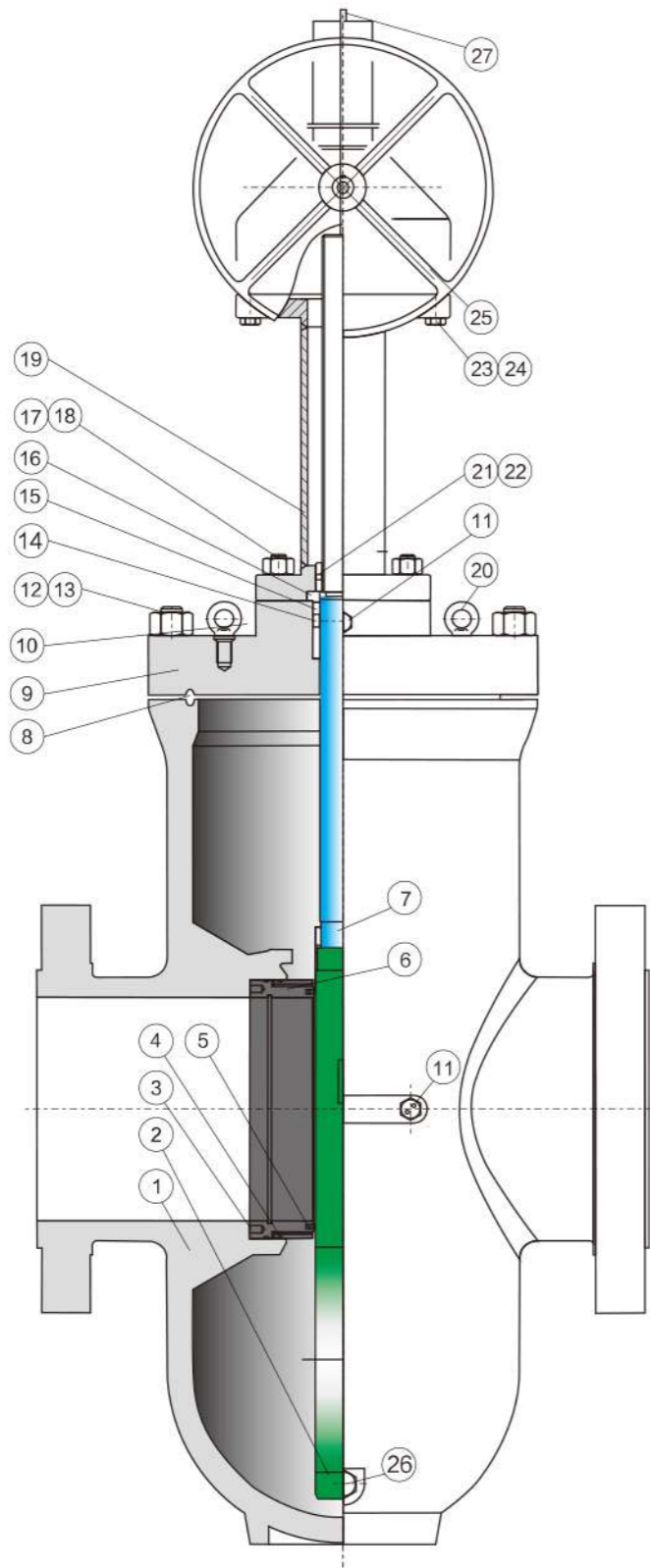

SLAB GATE VALVE

Material Specification



SUYAN VALVE

Item	Part Name	Material	
		Standard	Low Temperature
1	Body	A216 WCC	A352 LCC
2	Gate	A216 WCC + ENP	A352 LCC + ENP
3	Spring	INCONEL X-750	INCONEL X-750
4	O-Ring	VITON AED	HNBR
5	Seat Insert	NYLATRON GS	DEVLON
6	Seat	A105 + ENP	A350 LF2 + ENP
7	Stem	A564 TYPE 630, 17-4	A564 TYPE 630, 17-4
8	Gasket	SS/GRAPHITE	SS/GRAPHITE
9	Bonnet	A105	A350 LF2
10	Vent Valve	316SS	316SS
11	Grease Nipple	316SS	316SS
12	Nut	A194 2HM	A320 7M
13	Stud	A193 B7M	A320 L7M
14	Spacer Ring	A276 410	A276 410
15	Packing	VITON / DUCK	VITON / DUCK
16	Gland Flange	A216 WCC	A352 LCC
17	Nut	A194 2HM	A320 7M
18	Stud	A193 B7M	A320 L7M
19	Yoke	A105	A105
20	Lifting Bolt	A193 B7M	A320 L7M
21	Nut	A194 2HM	A320 7M
22	Screw	A193 B7M	A320 L7M
23	Hex Bolt	A193 B7M	A320 L7M
24	Spring Washer	SS/GRAPHITE	SS/GRAPHITE
25	Handwheel	CS	CS
26	Plug	316SS	316SS
27	Position Indicator	A276 410	A276 410

SLAB GATE VALVE

Dimension & Weight



SUYAN VALVE

150LB 300LB 600LB

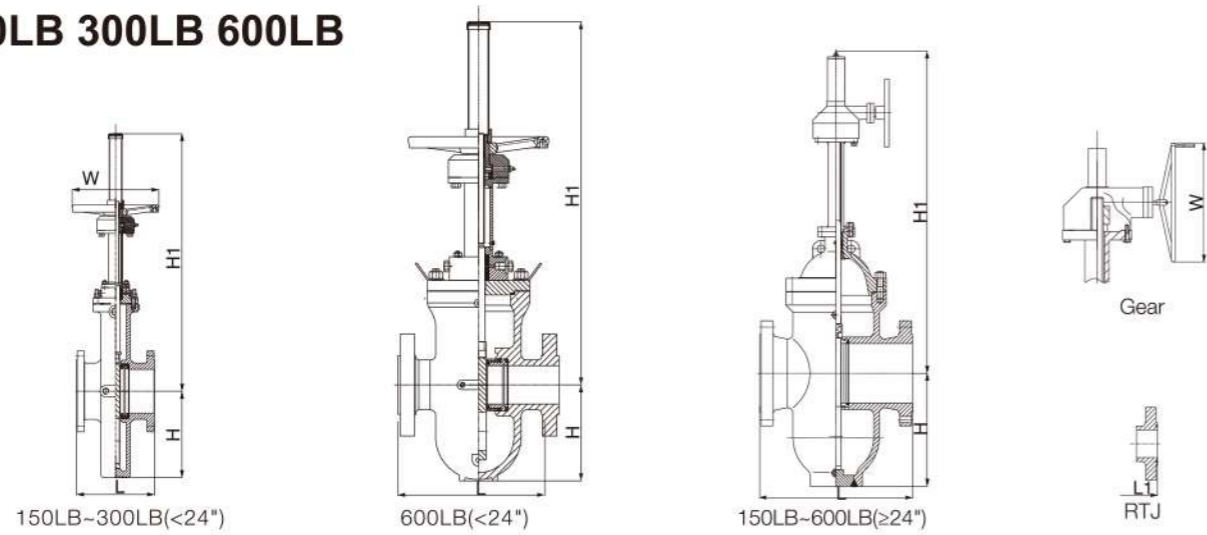

150LB

NPS	in	2	3	4	6	8	10	12	14	16	18	20	24	30	36	40	42	48
DN	mm	50	80	100	150	200	250	300	350	400	450	500	600	750	900	1000	1050	1200
L(RF)	in	7.00	8.00	9.00	10.50	11.50	13.00	14.00	15.00	16.00	17.00	18.00	20.00	25.59	31.50	36.00	38.00	44.00
	mm	178	203	229	267	292	330	356	381	406	432	457	508	650	800	914	965	1118
H	in	5.70	7.25	8.50	11.50	15.25	18.13	22.00	25.25	26.70	31.375	33.68	40.00	50.38	58.18	66.90	71.10	80.66
	mm	144.8	184	216	292	387	461	559	641	678	797	856	1016	1280	1478	1699	1806	2049
H1	in	19.04	23.28	25.4	32.30	41.48	49.84	57.6	60.81*	70.39*	76.21*	84.49*	100.3*	121.13*	140.99*	181.59	194.46	214.31
	mm	484	591	645	820	1054	1266	1463	1545*	1788*	1936*	2146*	2548*	3077*	3581*	4612	4939	5443
W	in	10.00	10.00	10.00	18.00	18.00	24.00	24.00	18.11*	18.11*	18.11*	18.11*	21.26*	24.00*	31.89*	31.89*	31.89*	31.89*
	mm	254	254	254	457	457	610	610	460*	460*	460*	460*	540*	610*	810*	810*	810*	810*
Weight	kg	38	51	57	102	166	234	307	424	622	836	1120	1417	2335	2940	3412	3865	5386

300LB

NPS	in	2	3	4	6	8	10	12	14	16	18	20	24	30	32	34	36	40	42	48
DN	mm	50	80	100	150	200	250	300	350	400	450	500	600	750	800	850	900	1000	1050	1200
L(RF)	in	8.50	11.13	12.00	15.88	16.50	18.00	19.75	30.00	33.00	36.00	39.00	45.00	55.00	60	64.02	67.99	75.98	67.99	67.99
	mm	216	283	305	403	419	457	502	762	838	914	991	1143	1397	1524	1626	1727	1930	2007	2286
H	in	5.7	7.17	8.63	11.73	15.13	18.25	22.00	23.79	27.50	30.50	34.40	40.75	50.00	53.12	55.66	57.31	63.1	67.79	77.31
	mm	144.8	182	219	298	384	464	559	604	699	775	874	1035	1270	1349	1414	1456	1603	1722	1964
H1	in	19.04	23.28	25.4	32.13	40.52	49.04	56.73	60.82*	67.92*	76.49*	83.26*	99.58*	122.44*	129.14	138.59	145.87	154.29	167.69	187.01
	mm	484	591	645	816	1029	1246	1441	1545*	1725*	1943*	2114*	2529*	3110*	3280	3520	3705	3919	4259	4750
W	in	10.00	10.00	10.00	18.00	18.00	24.00	24.00	18.11*	18.11*	21.26*	21.26*	24.00*	31.89*	31.89*	31.89*	31.89*	31.89*	31.89*	31.89*
	mm	254	254	254	457	457	610	610	460*	460*	540*	540*	610*	810*	810*	810*	810*	810*	810*	810*
Weight	kg	41	73	82	113	219	307	559	785	1026	1444	1735	2762	4618	5126	5476	5880	6824	7730	10772

600LB

NPS	in	2	3	4	6	8	10	12	14	16	18	20	24	26	30	36	40	42	48
DN	mm	50	80	100	150	200	250	300	350	400	450	500	600	650	750	900	1000	1050	1200
L(RF)	in	11.50	14.00	17	22.00	26.00	31.00	33.00	35.00	39.00	43.00	47.00	55.00	57.00	65.00	82.00	94.02	95.98	110
	mm	292	356	432	559	660	787	838	889	991	1092	1194	1397	1448	1651	2083	2388	2438	2794
L1(RTJ)	in	11.63	14.13	17.13	22.13	26.13	31.13	33.13	35.13	39.13	43.13	47.25	55.38	57.50	65.50	82.63	/	/	/
	mm	295	359	435	562	664	791	841	892	994	1095	1200	1407	1461	1664	2099	/	/	/
H	in	5.51	7.28	10.13	12.75	17.13	21.25	23.50	26.75	30.29	33.13	36.76	44.50	48.63	54.00	63.50	67.32	72.05	80.74
	mm	140	185	257	324	435	540	597	679	749	842	934	1130	1235	1372	1613	1710	1830	2051
H1	in	19.39	23.76	28.33	36.52	46.44	75.14	62.82*	68.02*	74.95*	80.13*	94.20*	111.20*	117.94*	131.66*	180.76*	196.83	210.24	232.12
	mm	493	604	720	928	1180	1909	1596*	1728*	1904*	2035*	2393*	2824*	2996*	3344*	4591*	4999	5340	5896
W	in	12.00	12.00	12.00	18.00	24.00	24.00	21.26*	24.00*	24.00*	24.00*	24.00*	31.89*	31.89*	31.89*	31.89*	31.89*	31.89*	31.89*
	mm	305	305	305	457	610	610	540*	610*	610*	610*	610*	810*	810*	810*	810*	810*	810*	810*
Weight	kg	49	86	151	244	440	787	1131	1571	1930	2653	3273	5482	6243	6848	12254	15200	18600	20600

* Gear Operator

SLAB GATE VALVE

Dimension & Weight



SUYAN VALVE

900LB 1500LB 2500LB

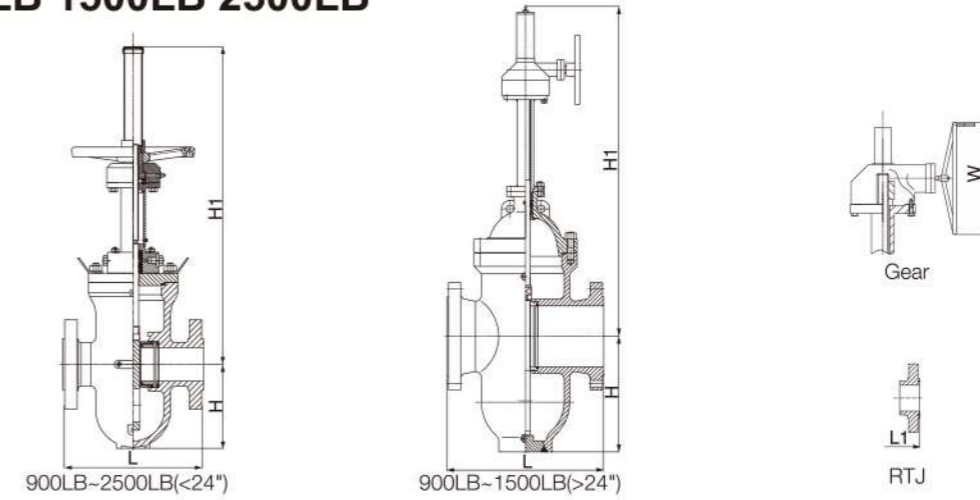

900LB

NPS	in	2	3	4	6	8	10	12	14	16	18	20	24
DN	mm	50	80	100	150	200	250	300	350	400	450	500	600
L(RF)	in	14.50	15.00	18.00	24.00	29.00	33.00	38.00	40.50	44.50	48.00	52.00	61.00
	mm	368	381	457	610	737	838	965	1029	1130	1219	1321	1549
L1(RTJ)	in	14.63	15.13	18.13	24.13	29.13	33.13	38.13	40.88	44.88	48.50	52.50	61.75
	mm	371	384	460	613	740	841	968	1038	1140	1232	1334	1568
H	in	5.06	7.04	10.25	13.13	17.25	21.75	24.38	27.88	30.00	33.62	37.90	45.50
	mm	129	179	260	334	438	553	619	708	762	854	963	1156
H1	in	17.75	23.76	29.42	36.56	46.29	55.14*	62.83*	67.44*	74.95*	84.73*	97.11*	111.70*
	mm	451	604	747	929	1176	1401*	1596*	1713*	1904*	2152*	2467*	2837*
W	in	12.00	18.00	18.00	18.00	24.00	21.26*	21.26*	24.00*	24.00*	31.89*	31.89*	31.89*
	mm	305	457	457	457	610	540*	540*	610*	610*	810*	810*	810*
Weight	kg	84	100	181	295	544	1029	1528	1891	2508	3309	5224	8016

1500LB

NPS	in	2	3	4	6	8	10	12	14	16	18	20	22	24
DN	mm	50	80	100	150	200	250	300	350	400	450	500	550	600
L(RF)	in	14.50	18.50	21.5	27.75	32.75	39.00	44.50	49.49	54.49	60.51	65.51	65.51	76.5
	mm	368	470	546	705	832	991	1130	1257	1384	1537	1664	1664	1943
L1(RTJ)	in	14.63	18.63	21.63	28.00	33.13	39.38	45.13	50.25	55.38	61.38	66.38	77.63	77.63
	mm	371	473	549	711	841	1000	1146	1276	1407	1559	1686	1972	1972
H	in	5.063	7.313	9.062	12.88	18.25	21.75	24.56	28.1	32.04	36.48	38.91	44.05	47.36
	mm	129	186	230	327	464	552	624	714	814	927	988	1119	1203
H1	in	17.75	23.875	28.50	31.50	44.38	53.22	57.72	68.45	77.9	93.65	116.48	125.14	140.5
	mm	451	606	724	800	1127	1352	1466	1739	1979	2379	2959	3179	3569
W	in	12.00	12	18.00	24.00	24.00	24.00	31.89*	31.89*	31.89*	31.89*	31.89*	31.89*	31.89*
	mm	305	305	457	610	610	610	810*	810*	810*	810*	810*	810*	810*
Weight	kg	56	112	162	453	1104	1815	2667	3717	4746	6075	8586	11907	13932

2500LB

NPS	in	2	3	4	6	8	10	12
DN	mm	50	80	100	150	200	250	300
L(RF)	in	17.76	22.76	26.50	35.98	40.24	50	55.98
	mm	451	578	673	914	1022	1270	1422
L1(RTJ)	in	17.88	23.00	26.88	36.50	40.88	50.88	56.88
	mm	454	584	683	927	1038	1292	1445
H	in	6.50	8.35	10.43	14.96	18.9	22.83	26.77
	mm	165	212	265	380	480	580	680
H1	in	27.76	32.09	36.42	53.94	58.46	70.28	77.17
	mm	705	815	925	1370	1485	1785	1960
W	in	12.00	12.00	24.00*	24.00*	31.89*	31.89*	31.89*
	mm	400	500	610*	610*	810*	810*	810*
Weight	kg	178	365	580	1440	2350	4100	5850

* Gear Operator



SUYAN VALVE

SUYAN GROUP

Through Conduit Expanding Gate Valve



Closed

In the full expanded closed position, the gate is wedged downward by the force, the segment stop has engaged with the lower body stop and expanding the gate and segment to form a tight seal by both seat faces against the upstream and downstream seats.

Mid Position

When operating towards the open position, the segment is wedged upward by the stem force on the gate to fully wedged with the gate and form a gap between gate & segment and the seat. This retracts the assembly so that it will slide freely between the seat faces.

Full Open

In the full expanded open position, the flow guide holes of gate and segment are precisely matched to ensure the path unobstructed. This expands the segment and the gate into the seats, isolating the flow from the cavity.

Optional Vent System

In the full expanded closed position, vent system will release the pressure when the body cavity overpressured.

Through Conduit Expanding Gate Valve are manufactured in accordance with API 6D.

THROUGH CONDUIT

EXPANDING GATE VALVE

Expanded View



SUYAN VALVE

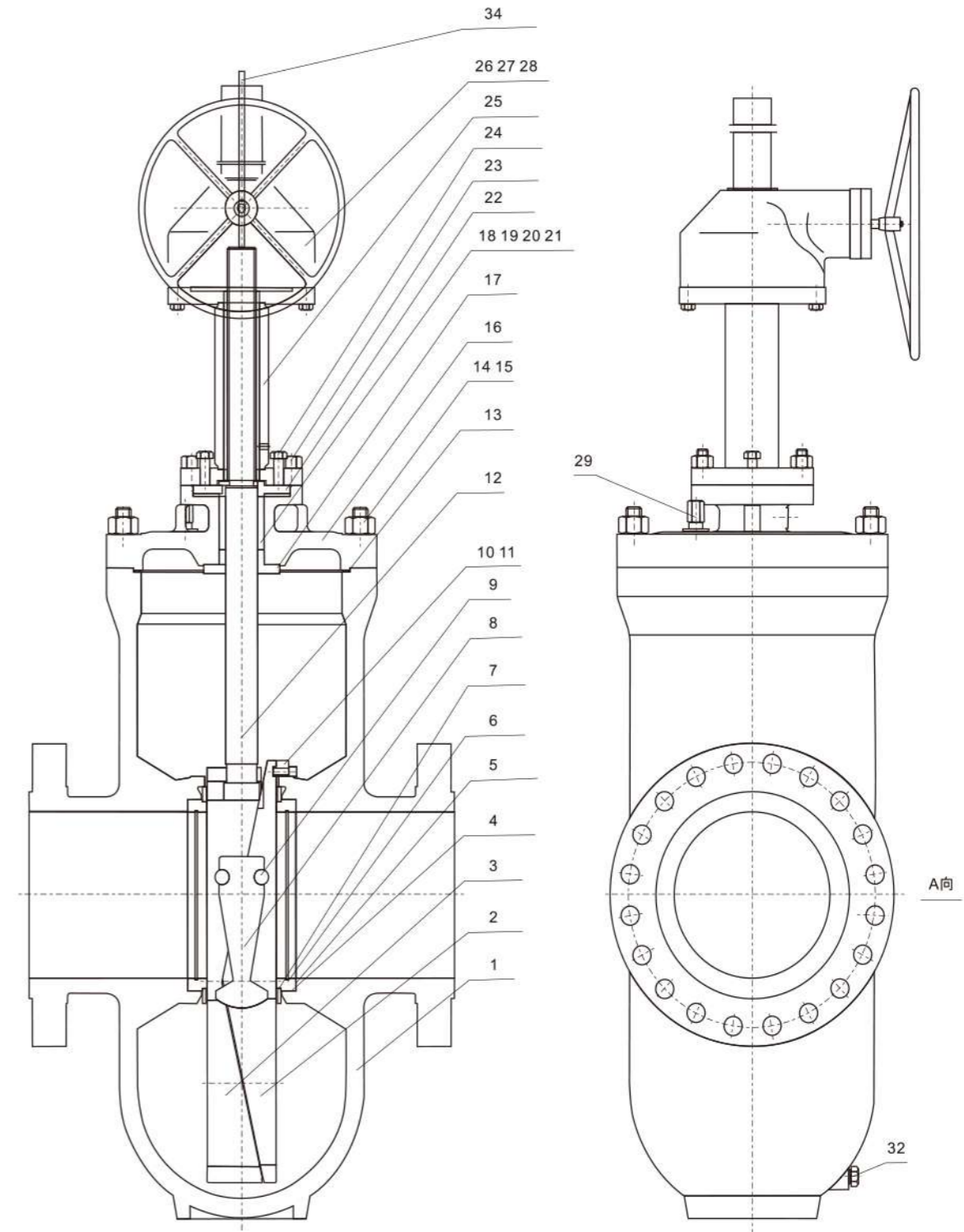

EXPANDING GATE VALVE

Material Specification



SUYAN VALVE

Item	Part Name	Material	
		Standard	Low Temperature
1	Body	A216 WCC	A352 LCC
2	Gate	A216 WCC + ENP	A352 LCC + ENP
3	Segment	A216 WCC + ENP	A352 LCC + ENP
4	O-Ring	VITON AED	HNBR
5	Seat	A105 + ENP	A350 LF2 + ENP
6	Fireproof Gasket	SS/GRAPHITE	SS/GRAPHITE
7	Guide Plate	A572 GR. 50	A572 GR. 50
8	Lever Lock Arm	A514 GR. B	A514 GR. B
9	Lever Arm Pin	4130	4130
10	Disc Segment Stop	A105	A105
11	Bolt	A193 B7M	A320 L7M
12	Stem	A564 TYPE 630, 17-4	A564 TYPE 630, 17-4
13	Gasket	SS/GRAPHITE	SS/GRAPHITE
14	Nut	A194 2HM	A320 7M
15	Stud	A193 B7M	A320 L7M
16	Bonnet	A105	A350 LF2
17	Backseat	A276 410	A350 LF2
18	O-Ring	VITON AED	HNBR
19	O-Ring	VITON AED	HNBR
20	Packing	VITON / DUCK	VITON / DUCK
21	Latern Ring	PEEK	PEEK
22	Gland Flange	A216 WCC	A352 LCC
23	Bolt	A193 B7M	A320 L7M
24	Bolt	A193 B7M	A320 L7M
25	Yoke	A105	A105
26	Gasket	SS/GRAPHITE	SS/GRAPHITE
27	Bolt	A193 B7M	A320 L7M
28	Handwheel	CS	CS
29	Drain Valve	316SS	316SS
30	Check Vale	316SS	316SS
31	Grease Nipple	316SS	316SS
32	Plug	316SS	316SS
33	Plug	316SS	316SS
34	Position Indicator	A276 410	A276 410

EXPANDING GATE VALVE

Dimension & Weight



SUYAN VALVE

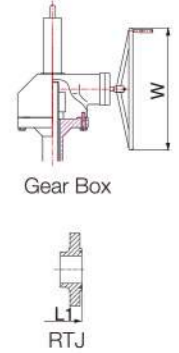
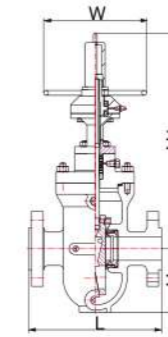
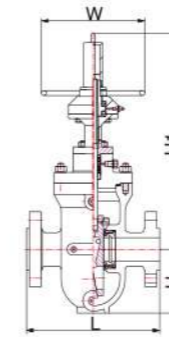

600LB

NPS	in	2	3	4	6	8	10	12	14	16	18	20	24	26	30	36	40	42	48
DN	mm	50	80	100	150	200	250	300	350	400	450	500	600	650	750	900	1000	1050	1200
L(RF)	in	11.50	14.00	17.00	22.00	26.00	31.00	33.00	35.00	39.00	43.00	47.00	55.00	57.00	65.00	82.00	94.02	95.98	110
	mm	292	356	432	559	660	787	838	889	991	1092	1194	1397	1448	1651	2083	2388	2438	2794
L1(RTJ)	in	11.63	14.13	17.13	22.13	26.13	31.13	33.13	35.13	39.13	43.13	47.25	55.38	57.50	65.50	82.63	/	/	/
	mm	295	359	435	562	664	791	841	892	994	1095	1200	1407	1461	1664	2099	/	/	/
H	in	5.51	7.28	10.13	12.75	17.13	21.25	23.50	26.75	30.29	33.13	36.76	44.50	48.63	54.00	63.50	67.32	72.05	80.74
	mm	140	185	257	324	435	540	597	679	749	842	934	1130	1235	1372	1613	1710	1830	2051
H1	in	19.39	23.76	28.33	36.52	46.44	75.14	62.82*	68.02*	74.95*	80.13*	94.20*	111.20*	117.94*	131.66*	180.76*	196.83	210.24	232.12
	mm	493	604	720	928	1180	1909	1596*	1728*	1904*	2035*	2393*	2824*	2996*	3344*	4591*	4999	5340	5896
W	in	12.00	12.00	12.00	18.00	24.00	24.00	21.26*	24.00*	24.00*	24.00*	24.00*	31.89*	31.89*	31.89*	31.89*	31.89*	31.89*	31.89*
	mm	305	305	305	457	610	610	540*	610*	610*	610*	610*	810*	810*	810*	810*	810*	810*	810*
Weight	kg	56	82	152	272	448	843	1093	1546	1973	2716	3836	6010	7345	9741	15581	16720	20460	22660

900LB

NPS	in	2	3	4	6	8	10	12	14	16	18	20	24
DN	mm	50	80	100	150	200	250	300	350	400	450	500	600
L(RF)	in	14.50	15.00	18.00	24.00	29.00	33.00	38.00	40.50	44.50	48.00	52.00	61.00
	mm	368	381	457	610	737	838	965	1029	1130	1219	1321	1549
L1(RF)	in	14.63	15.13	18.13	24.13	29.13	33.13	38.13	40.88	44.88	48.50	52.50	61.75
	mm	371	384	460	613	740	841	968	1038	1140	1232	1334	1568
H	in	5.063	7.04	10.25	13.13	17.25	21.75	24.38	27.88	30.00	33.62	37.90	45.50
	mm	129	179	260	334	438	553	619	708	762	854	963	1156
H1	in	17.75	23.76	29.42	36.56	46.29	55.14*	62.83*	67.44*	74.95*	84.73*	97.11*	111.70*
	mm	451	604	747	929	1176	1401*	1596*	1713*	1904*	2152*	2467*	2837*
W	in	12.00	18.00	18.00	18.00	24.00	21.26*	21.26*	24.00*	24.00*	31.89*	31.89*	31.89*
	mm	305	457	457	457	610	540*	540*	610*	610*	810*	810*	810*
Weight	kg	84	100	181	330	558	1077	1539	1891	2508	3309	5224	8016

1500LB

NPS	in	2	3	4	6	8	10	12	14	16	18	20	22	24
DN	mm	50	80	100	150	200	250	300	350	400	450	500	550	600
L(RF)	in	14.50	18.50	21.5	27.75	32.75	39.00	44.50	49.49	54.49	60.51	65.51	65.51	76.5
	mm	368	470	546	705	832	991	1130	1257	1384	1537	1664	1664	1943
L1(RTJ)	in	14.63	18.63	21.63	28.00	33.13	39.38	45.13	50.25	55.38	61.38	66.38	77.63	77.63
	mm	371	473	549	711	841	1000	1146	1276	1407	1559	1686	1972	1972
H	in	5.063	7.313	9.062	12.88	18.25	21.75	24.56	28.1	32.04	36.48	38.91	44.05	47.36
	mm	129	186	230	327	464	552	624	714	814	927	988	1119	1203
H1	in	17.75	23.875	28.50	31.50*	44.38*	53.22*	57.72*	68.45	77.9	93.65	116.48	125.14	140.5
	mm	451	606	724	800*	1127*	1352*	1466*	1739	1979	2379	2959	3179	3569
W	in	12.00	12	18.00	24.00*	24.00*	24.00*	30.00*	31.89*	31.89*	31.89*	31.89*	31.89*	31.89*
	mm	305	305	457	610*	610*	610*	762*	810*	810*	810*	810*	810*	810*
Weight	kg	95	112	253	453	1104	1815	2667	4089	5221	6683	9445	13098	15325

2500LB

NPS	in	2	3	4	6	8	10	12
DN	mm	50	80	100	150	200	250	300
L(RF)	in	17.76	22.76	26.5	35.98	40.24	50	55.98
	mm	451	578	673	914	1022	1270	1422
L1(RTJ)	in	17.88	23.00	26.88	36.50	40.88	50.88	56.88
	mm	454	584	683	927	1038	1292	1445
H	in	6.5	8.35	10.43	14.96	18.9	22.83	26.77
	mm	165	212	265	380	480	580	680
H1	in	27.76	32.09	36.42	53.94	58.46	70.28	77.17
	mm	705	815	925	1370	1485	1785	1960
W	in	12.00	12	18.00	24.00	24.00	24.00	30.00
	mm	400	500	600	600	600	600	800
Weight	kg	195	401	638	1584	2585	4510	6435

* Gear Operator

DIMENSION & WEIGHT

Cv Value



SUYAN VALVE

Flow coefficient Cv refers to the volume of water (in gal/min) flowing through the valve when the water temperatures is 5°C–40°C and the differential pressure between two ends of the valve is maintained at 1psi.

Size(NPS)	CLASS 300	CLASS 600	CLASS 900	CLASS 1500	CLASS 2500
2	432	378	337	337	218
2.5	/	682	558	558	305
3	1155	1109	1072	966	474
4	2176	1944	1890	1730	725
6	5300	4577	4383	3622	2510
8	11054	8886	8416	6879	5227
10	18856	14533	14087	11283	8313
12	28980	22729	21025	16843	12282
14	30883	28837	23846	20336	/
16	42224	39144	33358	27548	21396
18	55740	51368	45004	/	/
20	70386	64559	56871	/	/
22	86869	80279	/	/	/
24	106835	97240	84836	/	/
26	123222	114905	/	/	/
28	114355	135267	/	/	/
30	170229	157401	133706	/	/
36	245362	224424	/	/	/

Note: Data in this catalog may change from time to time due to product upgrading and technical improvement and Shu Yan reserves the right to change these data without prior notice. Shu Yan has no obligation to make additional change or inform users of any change to the product that has been sold.



SUYAN VALVE

SUYAN GROUP

Forged Steel Gate Valve



Design Feature

- Forged Steel Gate Valve are manufactured in accordance with API 602.
- Full port or Reduced port
- OS&Y, Outside screw and yoke
- The gland and gland flange self aligning design
- Bolted bonnet/Welded Bonnet/Pressure seal bonnet
- Integral backseat
- Socket welded (SW) ends to ASME B16.11
- Screwed ends (NPT) to ASME B1.20.1
- Flanges (RF/RT) according to ASME B16.5
- Integral flange or welded flange
- BW ends to ASME B16.25
- Low emission certified (optional)
- Cryogenic forged steel gate valve (optional)

FORGED STEEL

GATE VALVE

SW/NPT END

800LB 900LB 1500LB



SUYAN VALVE

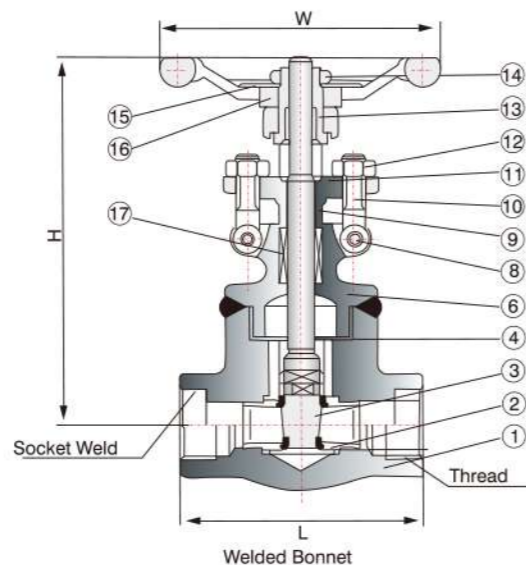
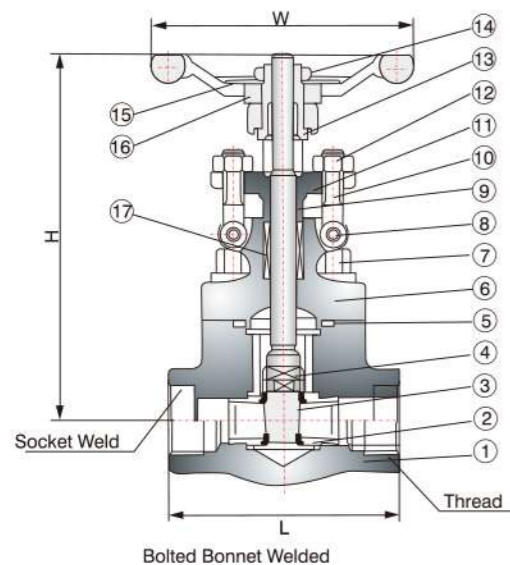

Material List

No.	Part Name	Cast Steel	Alloy Steel	Stainless Steel	
1	Body	A105N	A182 F22	A182 F304(L)	A182 F316(L)
2	Seat	A182 F6a+STL.6	A182 F304	A182 F304(L)	A182 F316(L)
3	Wedge	A182 F6a	A182 F304	A182 F304(L)	A182 F316(L)
4	Stem	A182 F6a	A182 F304	A182 F304(L)	A182 F316(L)
5	Gasket	SPW.SS304+Graphite	SPW.SS304+Graphite	SPW.SS304+Graphite	SPW.SS316+Graphite
6	Bonnet	A105N	A182 F22	A182 F304(L)	A182 F316(L)
7	Bonnet Bolt	A193 B7	A193 B16	A193 B8	A193 B8M
8	Pin	A276 410	A276 304	A276 304	A276 316
9	Gland	A276 410	A276 304	A276 304	A276 316
10	Gland Eyebolt	A193 B7	A193 B16	A193 B8	A193 B8M
11	Gland Flange	A105N	A182 F22	A182 F304(L)	A182 F316(L)
12	Gland Nut	A194 2H	A194 4	A194 8	A194 8M
13	Yoke Nut	A276 410	A276 410	A276 410	A276 410
14	H.W.Lock Nut	A194 2H	A194 4	A194 8	A194 8M
15	Nameplate	SS304	SS304	SS304	SS304
16	Handwheel	Ductile Iron	Ductile Iron	Ductile Iron	Ductile Iron
17	Stem Packing	Flexible graphite	Flexible graphite	PTFE	PTFE

Dimension and Weight

NPS	Conv.	Full	3/8"	1/2"	3/4"	1"	1 1/4"	1 1/2"	2"	2 1/2"	
			/	3/8"	1/2"	3/4"	1"	1 1/4"	1 1/2"	2"	
800LB	L	mm	76	76	92	106	120	114	144	170	
	H(OPEN)	mm	158	158	169	197	236	246	283	330	
	W	mm	100	100	100	125	160	160	160	200	
	Weight	Bolted	kg	2.0	2.1	2.3	4.3	5.9	6.9	11.1	15.2
		Welded	kg	1.7	1.8	2.0	3.8	5.1	6.1	10.2	14.2
900LB 1500LB	L	mm	111	111	111	120	120	140	170	210	
	H(OPEN)	mm	169	197	197	236	246	283	330	354	
	W	mm	125	125	125	160	160	180	200	210	
	Weight	Bolted	kg	2.5	4.2	4.3	6.6	8.8	12.5	17.2	23.5
		Welded	kg	2.4	4.0	4.2	6.3	8.7	12.1	17.2	22.0

FORGED STEEL

GATE VALVE

RF/BW END

150LB~1500LB



SUYAN VALVE

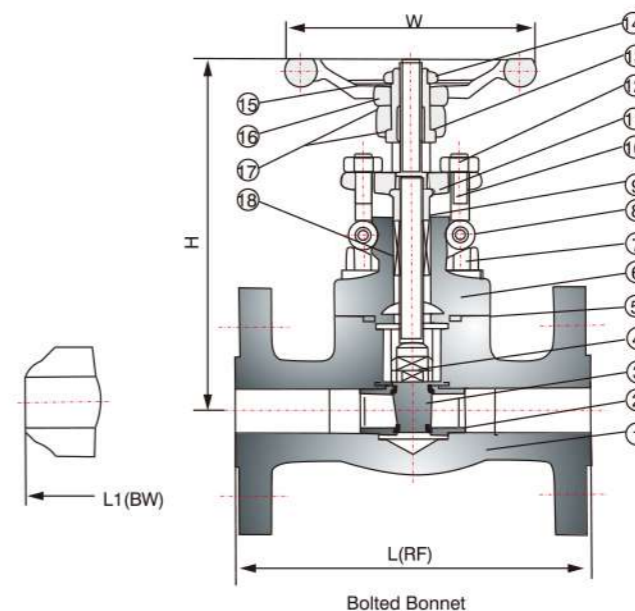

Material List

No.	Part Name	CS to ASTM	AS to ASTM	SS to ASTM	
		Type A105N	Type LF3	Type F304(L)	Type F316(L)
1	Body	A105N	A182 F22	A182 F304(L)	A182 F316(L)
2	Seat	A182 F6a+STL.6	A182 304	A182 304(L)	A182 316(L)
3	Wedge	A182 F6a	A182 F304	A182 F304(L)	A182 F316(L)
4	Stem	A182 F6a	A182 F304	A182 F304(L)	A182 F316(L)
5	Gasket	SPW.SS304+Graphite	SPW.SS304+Graphite	SPW.SS304+Graphite	SPW.SS316+Graphite
6	Bonnet	A105N	A182 F22	A182 F304(L)	A182 F316(L)
7	Bonnet Bolt	A193 B7	A193 B16	A193 B8	A193 B8M
8	Pin	A276 410	A276 304	A276 304	A276 316
9	Gland	A276 410	A276 304	A182 F304(L)	A182 F316(L)
10	Gland Eyebolt	A193 B7	A193 B16	A193 B8	A193 B8M
11	Gland Flange	A105N	A182 F22	A182 F304(L)	A182 F316(L)
12	Gland Nut	A194 2H	A194 4	A194 8	A194 8M
13	Yoke Nut	A276-410	A276-410	A276-410	A276-410
14	H.W.Lock Nut	A194 2H	A194 4	A194 8	A194 8M
15	Nameplate	SS	SS	SS	SS
16	Handwheel	Ductile Iron	Ductile Iron	Ductile Iron	Ductile Iron
17	Stem Packing	Flexible Graphite	Flexible Graphite	Flexible Graphite	Flexible Graphite

Dimension and Weight

NPS		mm	1/2	3/4	1	1 1/4	1 1/2	2
			150LB	L(RF)	108	117	127	140
	L1(BW)	108	117	127	140	165	178	
	H(OPEN)	mm	158	169	197	236	246	283
	W	mm	100	100	125	160	160	160
Weight	RF	kg	4.5	5.2	8.2	11.5	12.5	20.3
	BW	kg	2.8	3.3	5.4	7.1	8.2	12.5
300LB	L(RF)	mm	140	152	165	178	190	216
	L1(BW)	mm	140	152	165	178	190	216
	H(OPEN)	mm	158	169	197	236	246	283
	W	mm	100	100	125	160	160	160
	Weight	RF	kg	4.8	6.2	9.3	14	15.5
BW		kg	3.5	4.4	6.8	8.1	9.2	15.4
600LB	L(RF)	mm	165	190	216	229	241	292
	L1(BW)	mm	165	190	216	229	241	292
	H(OPEN)	mm	169	197	236	246	283	320
	W	mm	100	100	125	160	160	160
	Weight	RF	kg	5.9	7.4	10.4	16.2	17.5
BW		kg	4.5	5.1	8.2	10.5	12.4	20.1

NPS		mm	1/2	3/4	1	1 1/4	1 1/2	2
			900LB	L(RTJ)	216	229	254	279
	L1(BW)	mm	216	229	254	279	305	368
	H(OPEN)	mm	197	197	236	246	283	330
	W	mm	125	125	160	160	180	200
Weight	RTJ	kg	7.2	11.5	15.6	16.2	22.6	32.8
	BW	kg	5.2	9.3	12.4	13.8	18.9	27.5
1500LB	L(RTJ)	mm	216	229	254	279	305	371
	L1(BW)	mm	216	229	254	279	305	368
	H(OPEN)	mm	197	197	236	246	283	330
	W	mm	125	125	160	160	180	200
	Weight	RTJ	kg	7.2	11.5	15.6	16.2	22.6
BW		kg	5.2	9.3	12.4	13.8	18.9	27.5



SUYAN VALVE

SUYAN GROUP

Globe Valve GL Serie



SuYan GL series Globe Valve are manufactured in accordance with BS1873, API 623, ASME B16.34 specification and tested to API 598, and this series valves are of API 591 certified, and API624, ISO15848-1, TA Luft Certified. To ensure casting integrity, all pressure contain casting are from SuYan own foundry.

CAST STEEL



SUYAN VALVE

GL Series

Design Features

- Optional Bellow Seal
- Optional Double Packing With Lantern Ring
- Optional Live Loaded Gland Flange



MATERIAL LIST



SUYAN VALVE

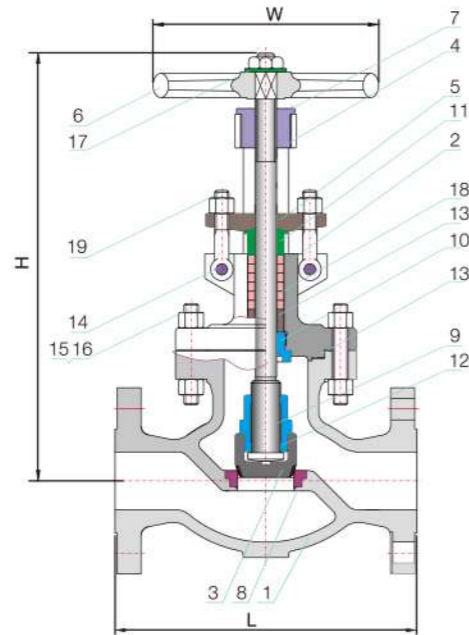

No.	Part	Standard	Stainless Steel	Low Temperature	High Temperature	Sour Service
1	Body	ASTM A216 WCB	ASTM A351 CF8M	ASTM A352 LCC	ASTM A217 WC9	ASTM A216 WCB
2	Bonnet	ASTM A216 WCB	ASTM A351 CF8M	ASTM A352 LCC	ASTM A217 WC9	ASTM A216 WCB
3	Disc	ASTM A182 F6a ASTM A105N+Cr13	ASTM A182 F316+STL.6	ASTM A350 LF2+STL.6	ASTM A182 F22+STL.6	ASTM A182 F6a(NACE)
4	Stem Nut	ASTM A439 D-2	ASTM A439 D-2	ASTM A439 D-2	ASTM A439 D-2	ASTM A439 D-2
5	Gland Flange	ASTM A216 WCB	ASTM A351 CF8M	ASTM A352 LCB	ASTM A217 WC9	ASTM A216 WCB
6	Handwheel	Ductile Iron	Ductile Iron	Ductile Iron	Ductile Iron	Ductile Iron
7	Screw	ASTM A193 B7	ASTM A193 B8	ASTM A320 L7	ASTM A193 B16	ASTM A193 B7M
8	Seat Ring	ASTM A105N+STL.6	ASTM A182 F316+STL.6	ASTM A350 LF2+STL.6	ASTM A182 F22+STL.6	ASTM A105N+STL.6
9	Stem	ASTM A182 F6a	ASTM A182 F316	ASTM A182 F316	ASTM A182 F6a	ASTM A182 F6a(NACE)
10	Back Seat	ASTM A276 410	ASTM A276 316	ASTM A276 316	ASTM A276 410	ASTM A276 410(NACE)
11	Gland	ASTM A276 410	ASTM A276 316	ASTM A276 316	ASTM A276 410	ASTM A276 410(NACE)
12	Disc Nut	ASTM A276 410	ASTM A276 316	ASTM A276 316	ASTM A276 410	ASTM A276 410(NACE)
13	Bonnet Gasket	SPW.SS+Graphite/RTJ.SS	SPW.SS+Graphite/RTJ.SS	SPW.SS+Graphite/RTJ.SS	SPW.SS+Graphite/RTJ.SS	SPW.SS+Graphite/RTJ.SS
14	Eye Bolt Pin	Carbon Steel	Stainless Steel	Stainless Steel	Stainless Steel	Carbon Steel
15	Bolt	ASTM A193 B7	ASTM A193 B8	ASTM A320 L7	ASTM A193 B16	ASTM A193 B7M
16	Nut	ASTM A194 2H	ASTM A194 8	ASTM A194 7	ASTM A194 4	ASTM A194 2HM
17	Handwheel Nut	ASTM A439 D-2	ASTM A439 D-2	ASTM A439 D-2	ASTM A439 D-2	ASTM A439 D-2
18	Packing	Graphite	Graphite	Graphite	Graphite	Graphite
19	Nut	ASTM A194 2H	ASTM A194 8	ASTM A194 7	ASTM A194 4	ASTM A194 2HM

GL SERIES GLOBE VALVE



SUYAN VALVE

150LB 300LB

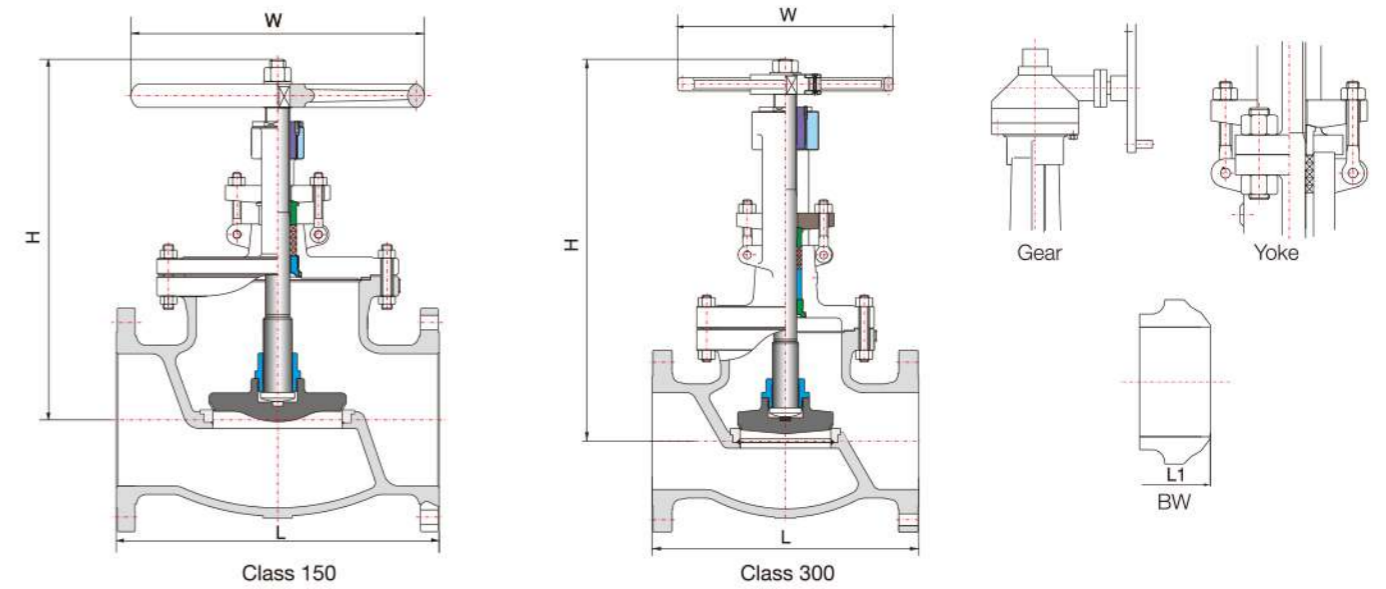

Class 150

NPS	in	2"	2-1/2"	3"	4"	5"	6"	8"	10"	12"	14"	16"	18"	20"	24"
DN	mm	50	65	80	100	125	150	200	250	300	350	400	450	500	600
L-L1 (RF-BW)	in	8	8.5	9.5	11.5	14	16	19.5	24.5	27.5	31	36	38.5	38.5	51
	mm	203.2	215.9	241.3	292.1	355.6	406.4	495.3	622.3	698.5	787.4	914.4	978	978	1295
W	in	7.9	7.9	9.8	11.8	13.8	13.8	17.7	17.7	25.2	25.2	28.3	*24	*24	*31.9
	mm	200	200	250	300	350	350	450	450	640	640	720	*610	*610	*810
H	in	12.7	15.0	14.8	17.0	18.3	19.7	21.8	25.4	27.8	30.3	32.5	44.9	49.7	60
	mm	322	382	376	433	466	501	553	645	707	770	825	1140	1263	1524
WT(RF)	kg	21	29	35	58	78	104	162	289	485	550	724	1400	2600	3700
WT(BW)	kg	17	20	30	47	71	86	138	219	362	491	650	1250	2300	3250

Class 300

NPS	in	2"	2-1/2"	3"	4"	5"	6"	8"	10"	12"	14"	16"	18"	20"
DN	mm	50	65	80	100	125	150	200	250	300	350	400	450	500
L-L1 (RF-BW)	in	10.5	11.5	12.5	14.0	15.7	17.5	22.0	24.5	28.0	33.0	34.0	38.5	40
	mm	266.7	292.1	317.5	355.6	400	444.5	558.8	622.3	711.2	838.2	863.6	978	1016
W	in	7.9	9.8	9.8	13.8	17.7	17.7	17.7	22.0	25.2	28.3	24	24	31.9
	mm	200	250	250	350	450	450	450	560	640	720	*610	*610	*810
H	in	13.8	15.9	16.0	18.6	22.0	22.6	31.5	32.4	35.1	36.0	55.2	57.5	64.3
	mm	350	404	406	473	560	574	801	822	891	914	1403	1460	1632
WT(RF)	kg	26	38	51	76	125	173	297	500	724	1125	1650	2700	3650
WT(BW)	kg	21	29	38	59	104	137	237	432	632	975	1450	2400	3200

* Gear Operator

GL SERIES GLOBE VALVE



SUYAN VALVE

600LB 900LB

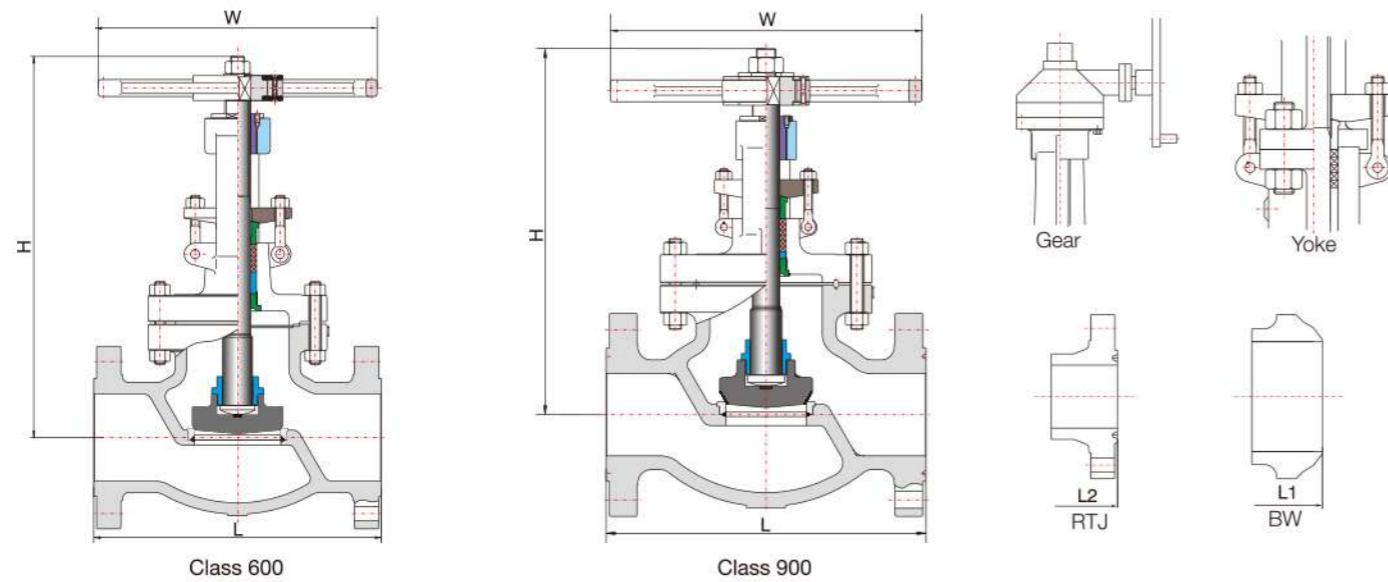

Class 600

NPS	in	2"	2-1/2"	3"	4"	5"	6"	8"	10"	12"	14"	16"	18"
DN	mm	50	65	80	100	125	150	200	250	300	350	400	450
L-L1 (RF-BW)	in	11.5	13	14	17.0	20	22	26	31	33	35	39	43
	mm	292	330.2	355.6	432	508	558.8	660.4	787.4	838.2	889	991	1092
L2(RTJ)	in	11.6	13.1	14.1	17.1	20.1	22.1	26.1	31.1	33.1	35.1	39.1	43.1
	mm	295.3	333	358.7	435.2	511	562	663.4	790.5	841.2	892	994	1095
W	in	9.8	13.8	13.8	17.7	19.7	19.7	25.2	28.3	28.3	*24	*31.9	*31.9
	mm	250	350	350	450	500	500	640	720	720	*610	*810	*810
H	in	16.4	20.7	21.1	23.6	27.6	28.7	34.4	36.1	38.3	55.1	63.4	70.9
	mm	416	526	537	600	700	730	875	918	972	1400	1610	1801
WT(RF)	kg	37	50	62	150	187	294	543	1006	1350	1620	2160	3300
WT(BW)	kg	30	40	58	132	142	227	460	729	1060	1330	1750	2800

Class 900

NPS	in	2"	2-1/2"	3"	4"	6"	8"	10"	12"	14"	16"
DN	mm	50	65	80	100	150	200	250	300	350	400
L-L1 (RF-BW)	in	14.5	16.5	15	18	24	29.0	33	38	40.5	44.5
	mm	368.3	419	381	457.2	609.6	736.6	838.2	965.2	1029	1130
L2(RTJ)	in	14.6	16.6	15.1	18.1	24.1	29.1	33.1	38.1	40.9	44.9
	mm	371.6	422	384.2	460.5	612.9	740	841.2	968.2	1038	1140
W	in	13.8	13.8	13.8	17.7	22.0	28.3	28.3	*31.9	*31.9	*31.9
	mm	350	350	350	450	560	720	720	*810	*810	*810
H	in	18.3	26.0	26.5	26.7	31.9	33.3	35.9	54.1	76.1	87
	mm	464	660	673	676	809	847	912	1374	1934	2210
WT(RF)	kg	95	138	110	197	435	720	1070	1920	2670	3520
WT(BW)	kg	75	85	112	158	360	597	890	1690	2390	3170

* Gear Operator

GL SERIES GLOBE VALVE



SUYAN VALVE

1500LB 2500LB

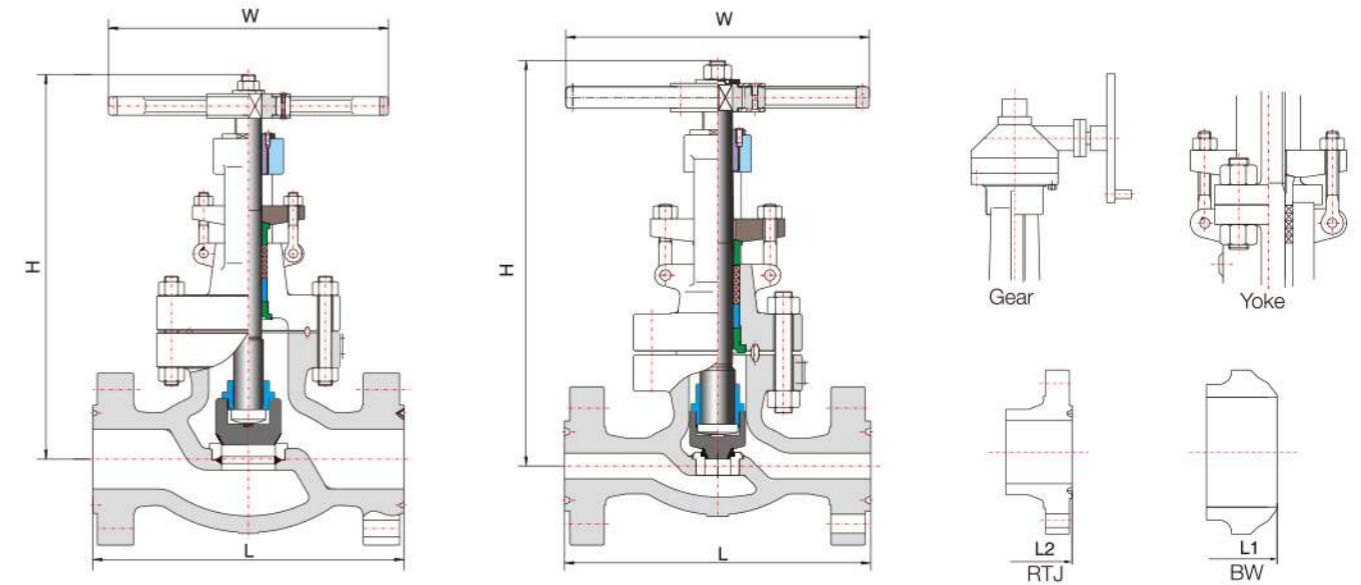

Class 1500

NPS	in	2"	2-1/2"	3"	4"	6"	8"	10"	12"
DN	mm	50	65	80	100	150	200	250	300
L-L1 (RF-BW)	in	14.5	16.5	18.5	21.5	27.8	32.8	39.0	44.5
	mm	368.3	419	469.9	546.1	704.9	832	991	1130
L2(RTJ)	in	14.6	16.6	18.6	21.6	28.0	33.1	39.4	45.1
	mm	371.6	422	473.2	549.3	711.2	841.5	1000	1146
W	in	13.8	13.8	17.7	19.7	24.0	31.9	31.9	31.9
	mm	350	350	450	500	*610	*810	*810	*810
H	in	18.3	22.5	25.4	29.7	34.7	49.6	96.5	114.3
	mm	464	572	646	755	882	1261	2450	2904
WT(RF)	kg	95	138	145	350	560	990	1530	2570
WT(BW)	kg	80	112	129	299	462	830	1330	2270

Class 2500

NPS	in	2"	2-1/2"	3"	4"	6"	8"	10"
DN	mm	50	65	80	100	150	200	250
L-L1 (RF-BW)	in	17.8	20	22.8	26.5	36	40.2	50
	mm	451	508	578	673	914	1022	1270
L2(RTJ)	in	17.9	20.2	23	26.9	36.5	40.9	50.9
	mm	454	514	584	683	927	1038	1292
W	in	17.7	19.7	22	24	24.0	31.9	31.9
	mm	450	500	560	610	*610	*810	*810
H	in	23.9	31.5	34.8	49.6	75	97	122.4
	mm	606.6	800	885	1260	1905	2465	3108
WT(RF)	kg	176	264	308	759	1990	4390	5290
WT(BW)	kg	141	214	238	644	1700	3950	4390

* Gear Operator



SUYAN VALVE

SUYAN GROUP

Forged Steel Globe Valve



SuYan forged steel globe valve are manufactured in accordance with API602, ISO15761 and ASME B16.34 and tested to API598. And forged steel globe valve are available in three bonnet designs: bolted bonnet, welded bonnet and pressure seal bonnet.

Design Feature

- Full port or Reduced port
- OS&Y, Outside screw and yoke
- The gland and gland flange self aligning design
- Bolted bonnet/Welded Bonnet/Pressure seal bonnet
- Integral type back seat
- Socket welded (SW) ends to ASME B16.11
- Screwed ends (NPT) to ASME B1.20.1.
- Flanges (RF/RT) according to ASME B16.5.
- Integral flange or welded flange
- BW ends to ASME B16.25
- Cryogenic forged steel gate valve (optional)
- Low emission design, conform to ISO15848-1 Class B (optional)
- Y-Pattern globe valve

FORGED STEEL

GATE VALVE

SW/NPT END

800LB 900LB 1500LB



SUYAN VALVE

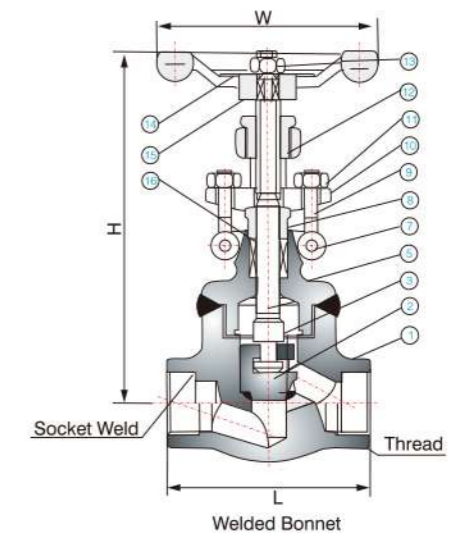
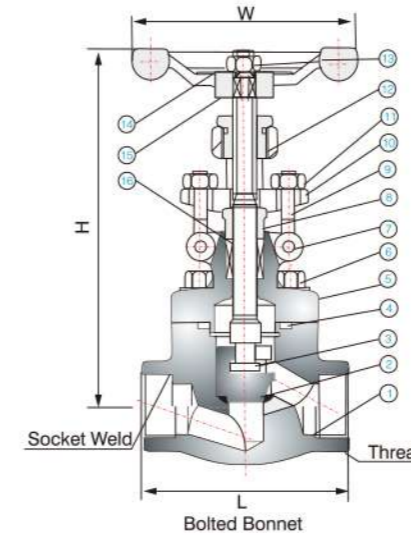

Material List

No.	Part Name	Cast Steel	Alloy Steel	Stainless Steel	
1	Body	A105N+STL.6	A182 F22+STL.6	A182 F304(L)+STL.6	A182 F316(L)+STL.6
2	Disc	A182 F6a	A182 F304	A182 F304(L)	A182 F316(L)
3	Stem	A182 F6a	A182 F304	A182 F304(L)	A182 F316(L)
4	Gasket	SPW.SS304+GT	SPW.SS304+GT	SPW.SS304+GT	SPW.SS304+GT
5	Bonnet	A105N	A182 F304	A182 F304(L)	A182 F316(L)
6	Bonnet Bolt	A193 B7	A193 B16	A193 B8	A193 B8M
7	Pin	A276 410	A276 304	A276 304	A276 316
8	Gland	A276 410	A276 304	A276 304	A276 316
9	Gland Eyebolt	A193 B7	A193 B16	A193 B8	A193 B8M
10	Gland Flange	A105N	A182 F22	A182 F304(L)	A182 F316(L)
11	Gland Nut	A194 2H	A194 4	A194 8	A194 8M
12	Yoke Nut	A276 410	A276 410	A276 410	A276 410
13	H.W.Lock Nut	A194 2H	A194 4	A194 8	A194 8M
14	Nameplate	SS304	SS304	SS304	SS304
15	Handwheel	Ductile Iron	Ductile Iron	Ductile Iron	Ductile Iron
16	Stem Packing	Flexible Graphite	Flexible Graphite	Flexible Graphite	Flexible Graphite

Dimension and Weight

NPS		Conv.	3/8"	1/2"	3/4"	1"	1 1/4"	1 1/2"	2"	/	
			/	3/8"	1/2"	3/4"	1"	1 1/4"	1 1/2"	2"	
800LB	L	mm	76	76	92	106	120	148	172	220	
	H(CLOSE)	mm	165	165	170	185	220	220	280	320	
	W	mm	100	100	100	125	160	160	180	200	
	Weight	Bolted	kg	1.9	1.9	2.1	3.5	6.0	7.5	11.4	14.6
		Welded	kg	1.7	1.7	2.1	3.5	6.0	7.5	11.4	14.6
	900LB	L	mm	111	111	111	120	152	172	220	
H(CLOSE)		mm	185	185	185	220	220	270	280		
W		mm	125	125	125	160	160	180	200		
Weight		Bolted	kg	2.2	3.7	3.6	6.8	7.6	11.6	15.0	
		Welded	kg	2.0	3.4	3.3	6.0	5.6	10.3	14.2	
1500LB		L	mm	111	111	111	120	152	172	220	
	H(OPEN)	mm	171	2.7	207	240	258	330	355		
	W	mm	125	125	125	160	160	180	200		
	Weight	Bolted	kg	2.2	3.7	3.6	6.8	7.6	11.6	15.0	
		Welded	kg	2.0	3.4	3.3	6.0	5.6	10.3	14.2	

GATE VALVE

SW/NPT END

900LB~2500LB



SUYAN VALVE

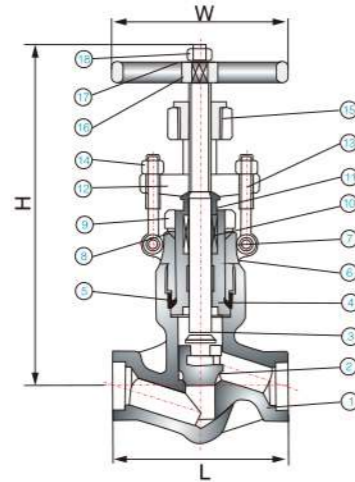

Pressure Seal Bonnet

Material List

No.	Part Name	Cast Steel	Alloy Steel	Stainless Steel	
1	Body	A105N+STL.6	A182 F22+STL.6	A182 F304(L)+STL.6	A182 F316(L)+STL.6
2	Disc	A182 F6a	A182 F304	A182 F304(L)	A182 316(L)
3	Stem	A182 F6a	A182 F304	A182 F304(L)	A182 F316(L)
4	Pressure Seat	A105N	A182 F304	A182 F304(L)	A182 F316(L)
5	Pressure Ring	A182 F6a	A182 F304	A182 F304(L)	A182 F316(L)
6	Bonnet	A105N	A182 F22	A182 F304(L)	A182 F316(L)
7	Pin	A276 410	A276 304	A276 304	A276 316
8	P.S. Washer	A105N	A182 F22	A182 F304(L)	A182 F316(L)
9	P.S. Lock Nut	A105N	A182 F22	A182 F304(L)	A182 F316(L)
10	Stem Packing	Flexible Graphite	Flexible Graphite	Flexible Graphite	Flexible Graphite
11	Gland	A276 410	A276 304	A276 304	A276 316
12	Gland Flange	A105N	A182 F22	A182 F304(L)	A182 F316(L)
13	Gland Eyebolt	A193 B7	A193 B16	A193 B8	A193 B8M
14	Gland Nut	A194 2H	A194 4	A194 8	A194 8M
15	Yoke Nut	A276 410	A276 410	A276 410	A276 410
16	Handwheel	Ductile Iron	Ductile Iron	Ductile Iron	Ductile Iron
17	Nameplate	SS304	SS304	SS304	SS304
18	Gland Nut	A194 2H	A194 4	A194 8	A194 8M

Dimension and Weight

	NPS		1/2"	3/4"	1"	1 1/4"	1 1/2"	2"
	L	mm						
900LB	L	mm	120	120	140	178	178	216
	H(Close)	mm	300	300	380	415	415	435
	W	mm	160	160	180	200	250	280
	Weight	kg	11.2	10.5	10.1	21.0	19.6	40.4
1500LB	L	mm	120	120	140	178	178	216
	H(Close)	mm	300	300	380	415	415	435
	W	mm	160	160	180	200	250	280
	Weight	kg	11.2	10.5	10.1	21.0	19.6	40.4
2500LB	L	mm	140	140	186	232	232	279
	H(Close)	mm	385	385	415	415	435	480
	W	mm	160	180	200	250	250	300
	Weight	kg	12.3	11.6	10.8	28.0	26.4	43.8

SUYAN GROUP

Swing Check Valve SC/SN Series



SuYan SC/SN series Swing Check Valve are manufactured in accordance with BS1868 or API 594 specification and tested to API 598, and this series valves are of API 591, AP I624, ASME B16.34, ISO15848-1 and TA Luft Certified. To ensure casting integrity, all pressure contain casting are from SuYan own foundry.

SC/SN Series

Design Features

- Optional Threaded or Welded Seat ring
- Optional Full Jacket or Semi-jacket Design
- Optional None Slam Design
- Optional Internal Hinge Pin or External Hinge Pin

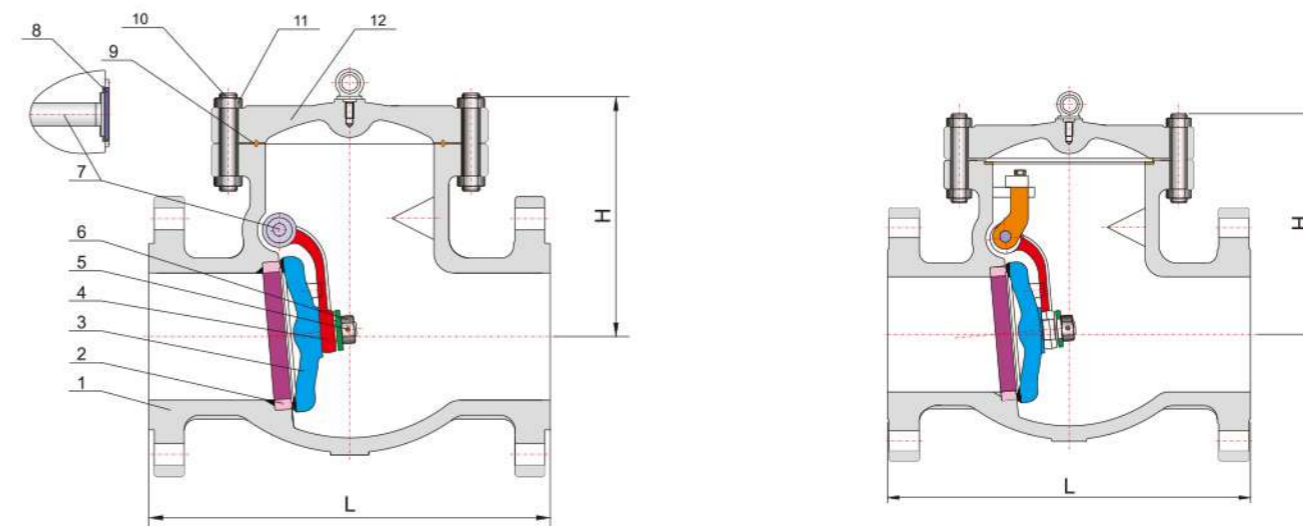

No.	Part	Standard	Stainless Steel	Low Temperature	High Temperature	Sour Service
1	Body	ASTM A216 WCB	ASTM A351 CF8M	ASTM A352 LCC	ASTM A217 WC9	ASTM A216 WCB
2	Seat Ring	ASTM A105N+STL.6	ASTM A182 F316+STL.6	ASTM A350 LF2+STL.6	ASTM A182 F22+STL.6	ASTM A105N+STL.6
3	Disc	ASTM A216 WCB+Cr13	ASTM A351 CF8M	ASTM A352 LCC+STL.6	ASTM A217 WC9+STL.6	ASTM A216 WCB+Cr13(NACE)
4	Hinge	ASTM A216 WCB	ASTM A351 CF8M	ASTM A352 LCC	ASTM A217 WC9	ASTM A216 WCB
5	Pin	ASTM A276 410	ASTM A276 316	ASTM A276 316	ASTM A276 410	ASTM A276 410(NACE)
6	Disc Nut	ASTM A276 410	ASTM A276 316	ASTM A276 316	ASTM A276 410	ASTM A276 410(NACE)
7	Hinge Pin	ASTM A182 F6a	ASTM A276 316	ASTM A182 F316	ASTM A276 420	Stainless Steel
8	Plug	ASTM A105N	ASTM A182 F316	ASTM A350 LF2	ASTM A182 F22	ASTM A105N
9	Gasket	SPW.SS+Graphite/RTJ.SS	SPW.SS+Graphite/RTJ.SS	SPW.SS+Graphite/RTJ.SS	SPW.SS+Graphite/RTJ.SS	SPW.SS+Graphite/RTJ.SS
10	Bonnet Bolt	ASTM A193 B7	ASTM A193 B8	ASTM A320 L7	ASTM A193 B16	ASTM A193 B7M
11	Bonnet Nut	ASTM A194 2H	ASTM A194 8	ASTM A194 7	ASTM A194 4	ASTM A194 2HM
12	Cover	ASTM A216 WCB	ASTM A351 CF8M	ASTM A352 LCC	ASTM A219 WC9	ASTM A216 WCB

SC/SN SERIES SWING CHECK VALVE



SUYAN VALVE

150LB 300LB

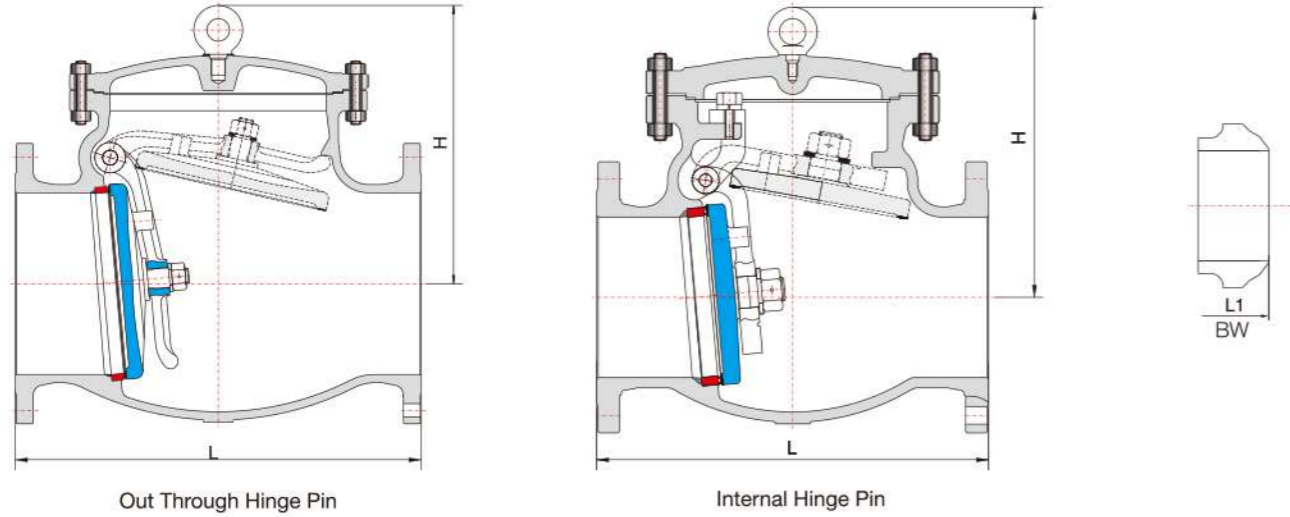

Class 150

NPS	in	2"	2-1/2"	3"	4"	5"	6"	8"	10"	12"	14"	16"	18"	20"	24"	26"	28"	30"	32"	36"	40"	42"	48"
DN	mm	50	65	80	100	125	150	200	250	300	350	400	450	500	600	650	700	750	800	900	1000	1050	1200
L-L1 (RF-BW)	in	8	8.5	9.5	11.5	13	14	19.5	24.5	27.5	31	34	38.5	38.5	51	51	57	60	68	77	85	89	101
	mm	203.2	215.9	241.3	292.1	330.2	355.6	495.3	622.3	698.5	787.4	863.6	977.9	977.9	1295	1295	1448	1524	1727	1956	2159	2261	2566
H	in	6.0	6.7	7.1	8.4	10.6	12.2	14.4	17.0	19.8	22.1	23.3	27.6	28.7	32.6	35.3	36.8	38.2	49.1	54.2	55.5	57.8	64.6
	mm	153	169	181	213	268	309	367	432	502	561	592	702	727.9	826.8	897	935	970	1058	1377	1410	1468	1642
WT(RF)	kg	15	22	28	42	57	79	131	177	282	380	542	632	855	970	1276	1600	2020	2430	3130	4260	5030	6680
WT(BW)	kg	10	12	17	29	45	57	96	143	227	294	468	552	755	831	1120	1420	1760	2130	2930	3730	4430	5680

Class 300

NPS	in	2"	2-1/2"	3"	4"	5"	6"	8"	10"	12"	14"	16"	18"	20"	24"	26"	28"	30"	32"	36"	40"	42"	48"
DN	mm	50	65	80	100	125	150	200	250	300	350	400	450	500	600	650	700	750	800	900	1000	1050	1200
L-L1 (RF-BW)	in	10.5	11.5	12.5	14	15.8	17.5	21	24.5	28	33	34	38.5	40	53	53	59	62.8	68	82	96	103	124.1
	mm	266.7	292.1	317.5	355.6	400.1	444.5	533.4	622.3	711.2	838.2	863.6	977.9	1016	1346.2	1346	1499	1594	1727	2083	2438	2617	3151
H	in	7.0	7.2	9.1	10.5	11.2	12.7	15.5	17.9	21.3	24.0	25.7	28.2	31.4	35.3	36.6	45.8	50	50	59.4	68.9	73.6	87.8
	mm	177	182	231	266	285	323	393	454	541	608.5	653	716	796.3	896	930	1163	1270	1270	1510	1750	1870	2230
WT(RF)	kg	20	30	40	65	84	118	193	310	450	595	840	933	1320	1848	2375	2660	3680	3680	5030	6290	7050	9310
WT(BW)	kg	16	22	30	53	73	101	157	232	414	455	766	774	960	1792	1995	2260	2780	2780	4430	5640	6150	8310

SC/SN SERIES SWING CHECK VALVE



SUYAN VALVE

600LB 900LB

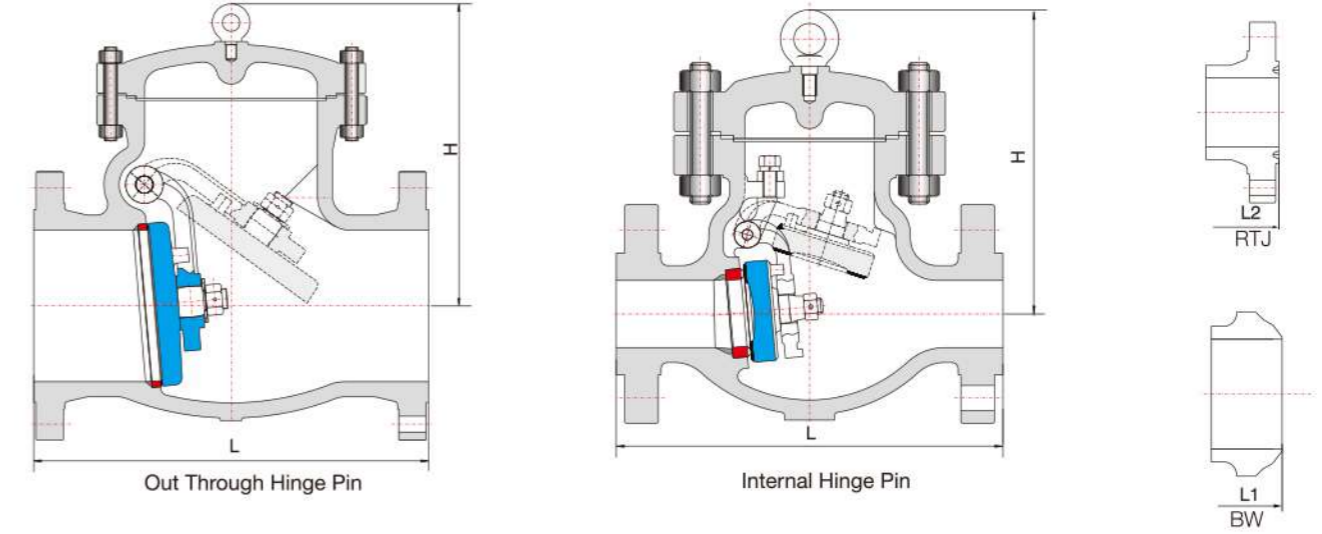

Class 600

NPS	in	2"	2-1/2"	3"	4"	5"	6"	8"	10"	12"	14"	16"	18"	20"	24"	26"	28"	30"	32"	36"	40"	42"	48"
DN	mm	50	65	80	100	125	150	200	250	300	350	400	450	500	600	650	700	750	800	900	1000	1050	1200
L-L1 (RF-BW)	in	11.5	13	14	17	20	22	26	31	33	35	39	43	47	55	57	63	65	70	82	90	96	100
	mm	292.1	330.2	355.6	431.8	508	558.8	660.4	787.4	838.2	889	990.6	1092.2	1193.8	1397	1448	1600	1651	1778	2083	2286	2438	2540
L2(RTJ)	in	11.6	13.1	14.1	17.1	20.1	22.1	26.1	31.1	33.1	35.1	39.1	43.1	47.3	55.4	57.5	63.5	65.5	70.6	82.6			
	mm	295.3	333	358.7	435.2	511	562	663.4	790.5	841.2	892	993.6	1095.2	1200.2	1406.7	1461	1613	1664	1794	2099			
H	in	9.2	9.8	10.8	12.2	15.3	15.6	18.4	21.8	23.2	26	28.3	31.9	32.7	38.2	43.7	46.9	52.1	53.8	60.7	67.0	70.9	85.5
	mm	233	249	274	311	389	397	467	554	589	660	719	811	831	971	1110	1192	1324	1367	1542	1702	1800	2171
WT(RF)	kg	30	43	55	93	160	208	339	547	715	885	1310	1620	2120	3100	3800	4600	5500	6800	8100	8900	9900	11100
WT(BW)	kg	21	35	43	64	115	145	256	375	589	694	932	1279	1702	2497	3100	3900	4700	6000	7200	8100	9800	10200

Class 900

NPS	in	2"	2-1/2"	3"	4"	6"	8"	10"	12"	14"	16"	18"	20"	24"	26"	28"	30"	32"	36"
DN	mm	50	65	80	100	150	200	250	300	350	400	450	500	600	650	700	750	800	900
L-L1 (RF-BW)	in	14.5	16.5	15	18	24	29	33	38	40.5	44.5	48.0	52.0	61.0	65.0	69.0	73.0	77.0	84.9
	mm	368.3	419	381	457.2	610	736.6	838.2	965.2	1029	1130	1219	1321	1549	1651	1753	1854	1956	2156
L2(RTJ)	in	14.6	16.6	15.1	18.1	24.1	29.1	33.1	38.1	40.9	44.9	48.5	52.5	61.7	65.9	69.9	73.9	/	/
	mm	371.6	422	384.2	460.5	612.9	740	841.2	968.2	1038	1140	1232	1333	1568	1673	1775	1876	/	/
H	in	11.2	11.8	11.9	12	16.7	20	22.9	25.6	27	33.0	33.0	36.4	36.7	44.1	54	59.9	65.8	71.7
	mm	284	300	301	305	423	507	582	650	686	838	839	924	932	1121	1372	1521	1671	1821
WT(RF)	kg	70	100	110	150	305	510	810	1120	1380	1900	3000	4000	5200	6600	7550	8850	10150	12750
WT(BW)	kg	50	68	77	113	230	387	632	901	1139	1613	2650	3550	4650	5630	6420	7510	8600	10780

SC/SN SERIES SWING CHECK VALVE



SUYAN VALVE



SUYAN VALVE

1500LB 2500LB

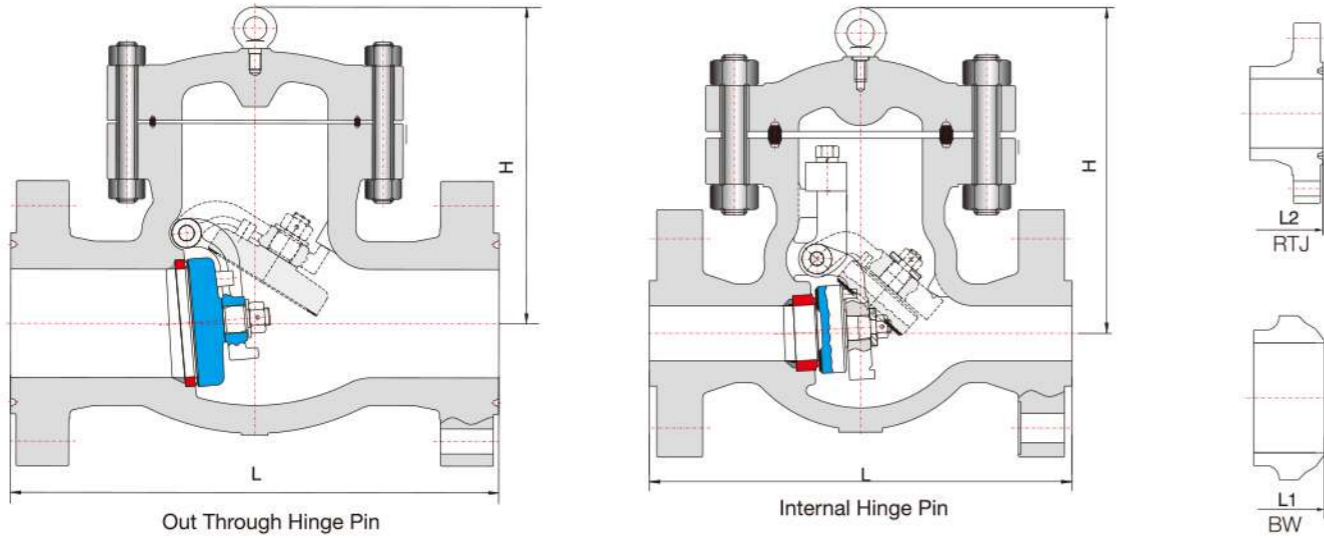

Class 1500

NPS	in	2"	2-1/2"	3"	4"	6"	8"	10"	12"	14"	16"	18"	20"	24"	26"	28"	30"
DN	mm	50	65	80	100	150	200	250	300	350	400	450	500	600	650	700	750
L-L1 (RF-BW)	in	14.5	16.5	18.5	21.5	27.8	32.8	39	44.5	49.5	54.5	60.5	65.5	76.5	82.0	87.5	93.0
	mm	368.3	419	469.9	546.1	704.9	832	990.6	1130.3	1257	1384	1537	1664	1943	2083	2222.5	2362
L2(RTJ)	in	14.6	16.6	18.6	21.6	28	33.1	39.4	45.1	50.2	55.4	61.4	66.4	77.6			
	mm	371.6	422	473.2	549.4	711.2	841.5	1000	1146	1276	1407	1559	1686	1972			
H	in	11.2	11.8	13.1	14.7	19.8	23.9	25.6	30.7	37.4	40.2	45.2	47.5	60.6	70.6	80.7	90.7
	mm	284	300	332	373	502	608	649	779	950	1020	1147	1206	1539	1794	2049	2304
WT(RF)	kg	70	100	150	245	550	1010	1476	2280	3060	4500	6100	8000	9800	11600	13400	15200
WT(BW)	kg	50	77	115	190	452	750	1012	1780	2290	3500	5200	7500	8400	9300	10200	11100

Class 2500

NPS	in	2"	2-1/2"	3"	4"	6"	8"	10"	12"	14"	16"	18"	20"	24"
DN	mm	50	65	80	100	150	200	250	300	350	400	450	500	600
L-L1 (RF-BW)	in	17.8	20	22.8	26.5	36	40.2	50	56	62	68	73.9	79.9	91.9
	mm	451	508	578	673	914	1022	1270	1422	1575	1727	1877	2029	2334
L2(RTJ)	in	17.9	20.2	23	26.9	36.5	40.9	50.9	56.9					
	mm	454	514	584	683	927	1038	1292	1445					
H	in	16.4	16.5	17.4	18.9	20.1	28	33.5	39.4	47.2	51.2	55.1	59.1	63
	mm	416	419	441	479	511	711	851	1000	1200	1300	1400	1500	1600
WT(RF)	kg	145	240	330	650	806	2420	3750	5500	7400	9010	11200	12700	14000
WT(BW)	kg	110	190	260	535	665	1980	2980	4350	6200	8250	9400	11890	13000

SUYAN GROUP

Dual Plate Check Valve SDP Series



SuYan manufactured in accordance with API 594, ASME B16.34 specification and tested to API 598. To ensure casting integrity, all pressure contain casting are from SuYan own foundry.

SDP SERIES DUAL PLATE CHECK VALVE

150LB 300LB

SDP Series

Design Features

- Retainerless Design
- Optional End connection Wafer, Lug, Double Flange

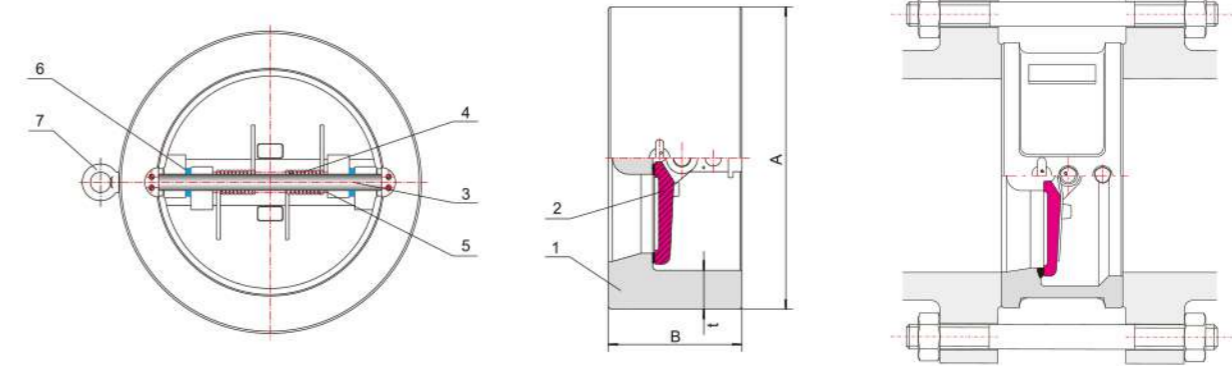

Class 150

Size		A		B		t		NO.	Stud Details				End Facing	Weight	
NPS	DN	in	mm	in	mm	in	mm		Diameter		RF Stud Length			lbs	kg
2"	50	4.1	104	2.4	60	0.34	8.6	4	0.6	16	5.8	146	RF	5.9	2.9
2 1/2"	65	4.8	123	2.6	67	0.38	9.7	4	0.6	16	6.3	159	RF	10.8	4.9
3"	80	5.4	136	2.9	73	0.41	10.4	4	0.6	16	6.8	171	RF	10.8	4.9
4"	100	6.9	174	2.9	73	0.44	11.2	8	0.6	16	6.8	171	RF	17.6	7.8
5"	125	7.7	196	3.4	86	-	-	8	0.8	19	7.5	191	RF	27.4	12.7
6"	150	8.7	221	3.9	98	0.47	11.9	8	0.8	19	8	203	RF	30.4	13.7
8"	200	10.9	278	5	127	0.50	12.7	8	0.8	19	9.5	241	RF	55.9	25.5
10"	250	13.4	339	5.8	146	0.56	14.2	12	0.9	22	10.5	267	RF	96	44.1
12"	300	16.1	408	7.1	181	0.63	16.0	12	0.9	22	12.3	311	RF	137.2	62.7
14"	350	17.7	449	7.3	184	0.66	16.8	12	1	25	12.8	324	RF	166.6	75.5
16"	400	20.1	511	7.5	191	0.69	17.5	16	1.1	29	13.3	337	RF	225.4	101.9
18"	450	21.6	549	8	203	0.72	18.3	16	1.1	29	14.3	362	RF	264.6	120.5
20"	500	23.9	606	8.6	219	0.75	19.1	20	1.3	32	15.3	387	RF	352.8	159.7
24"	600	28.3	718	8.8	222	0.81	20.6	20	1.3	32	16	406	RF	470.4	213.6
28"	700	32.8	832	12	305	-	-	28	1.3	32	24.5	622	RF	1176	533.1
30"	750	34.8	883	12	305	0.91	23.1	28	1.3	32	21.8	552	RF	980	444.9
32"	800	37	940	12	305	-	-	28	1.5	38	24.8	629	RF	1372	622.3
36"	900	41.3	1048	14.5	368	1	25.4	32	1.5	38	26	660	RF	1715	778.1
40"	1000	45.8	1162	17	432	-	-	36	1.5	38	28.5	724	RF	2548	1155
42"	1050	48	1219	17	432	1.1	27.7	36	1.5	38	29	737	RF	2793	1267
48"	1200	54.5	1384	20.6	524	1.2	30.2	44	1.5	38	31	787	RF	4312	1956
54"	1350	61	1549	23.3	591	-	-	44	1.8	44	35.8	908	RF	5390	2445
60"	1500	67.5	1715	26	660	-	-	52	1.8	44	38.8	984	RF	7056	3200

MATERIAL LIST

No.	Part	Standard	Stainless Steel	Low Temperature	High Temperature	Sour Service
1	Body	ASTM A216-WCB+STL6	ASTM A351-CF8M +STL6	ASTM A352-LCC +STL6	ASTM A217-WC9 +STL6	ASTM A216-WCB+STL6
2	Disc	ASTM A216-WCB/Cr13	ASTM A351-CF8M	ASTM A352-LCC/316 Overlay	ASTM A217-WC9/STL6 overlay	ASTM A216-WCB/Cr13-NC
3	Stem	ASTM A182-F6a	ASTM A182-F316	ASTM A182-F316	ASTM A182-F6a	ASTM A182-F6a-NC
4	Spring	Inconel X-750	Inconel X-750	Inconel X-750	Inconel X-750	Inconel X-750
5	Spring Retainer	ASTM A182-F6a	ASTM A182-F316	ASTM A182-F316	ASTM A182-F6a	ASTM A182-F6a-NC
6	Lantern Ring	ASTM A182-F6a	ASTM A182-F316	ASTM A182-F316	ASTM A182-F6a	ASTM A182-F6a-NC
7	Eye Bolt	Carbon Steel	Stainless Steel	Carbon Steel	Carbon Steel	Carbon Steel

Class 300

Size		A		B		t		NO.	Stud Details				End Facing	Weight	
NPS	DN	in	mm	in	mm	in	mm		Diameter		RF Stud Length			lbs	kg
2"	50	4.4	111	2.4	60	0.38	9.7	8	0.63	16	6	152	RF	6.4	2.9
2 1/2"	65	5.1	129	2.6	67	0.44	11.2	8	0.75	19	6.8	171	RF	12.7	5.9
3"	80	5.9	149	2.9	73	0.47	11.9	8	0.75	19	7.3	184	RF	12.7	5.9
4"	100	7.1	180	2.9	73	0.50	12.7	8	0.75	19	7.5	191	RF	17.6	7.8
5"	125	8.5	215	3.4	86	-	-	8	0.75	19	8.3	210	RF	27.4	12.7
6"	150	9.8	250	3.9	98	0.63	16	12	0.75	19	9	229	RF	39.2	17.6
8"	200	12.1	308	5	127	0.69	17.5	12	0.88	22	10.8	273	RF	66.6	30.4
10"	250	14.2	360	5.8	146	0.75	19.1	16	1	25	12.3	311	RF	107.8	49
12"	300	16.6	421	7.1	181	0.81	20.6	16	1.1	29	14.3	362	RF	166.6	75.5
14"	350	19.1	484	8.8	222	0.88	22.4	20	1.1	29	16	406	RF	284.2	129.4
16"	400	21.2	538	9.1	232	0.94	23.9	20	1.3	32	17	432	RF	392	177.4
18"	450	23.5	597	10.4	264	1	25.4	24	1.3	32	18.5	470	RF	509.6	231.3
20"	500	25.8	654	11.5	292	1.1	26.9	24	1.3	32	20	508	RF	686	311.6
24"	600	30.5	775	12.5	318	1.2	30.2	24	1.5	38	22	559	RF	1029	466.5
28"	700	35.4	899	14.5	368	-	-	28	1.6	41	26.5	673	RF	1470	666
30"	750	37.5	953	14.5	368	1.4	35.1	28	1.8	44	26.8	679	RF	1617	733
32"	800	39.6	1006	14.5	368	-	-	28	1.9	48	29	737	RF	1960	888
36"	900	44	1118	19	483	1.6	39.9	32	2	51	73.8	832	RF	2646	1200
40"	1000	43.9	1114	21.5	546	-	-	32	1.6	41	35.3	895	RF	3332	1511
42"	1050	45.9	1165	22.4	568	1.8	44.7	32	1.6	41	36.5	927	RF	4116	1866
48"	1200	52.1	1324	24.8	629	2	49.5	32	1.9	48	40.5	1029	RF	7203	3267

SDP SERIES DUAL PLATE CHECK VALVE

600LB 900LB 1500LB

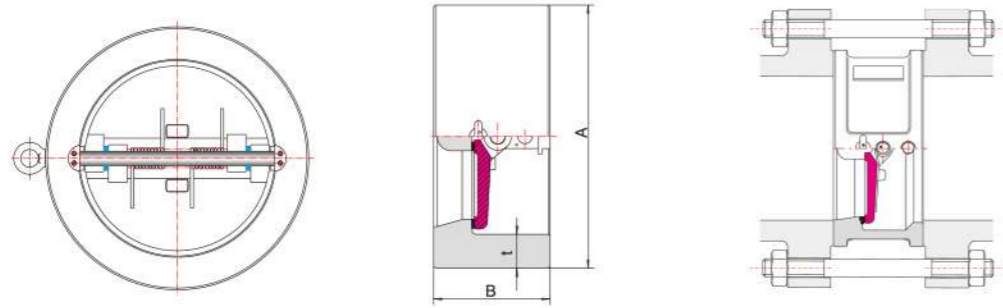

Class 600

Size		A		B		t		NO.	Stud Details				End Facing	Weight			
NPS	DN	in	mm	in	mm	in	mm		Diameter	RF Stud Length	RTJ Stud Length	RF Stud Length		RTJ Stud Length	lbs	kg	
									in	mm	in	mm		in	mm		
2"	50	4.4	111	2.4	60	0.44	11.2	8	0.63	16	6.5	165	7	178	RF/RTJ	6.4	2.9
3"	80	5.8	148	2.9	73	0.50	12.7	8	0.75	19	7.8	197	8.3	210	RF/RTJ	12.7	5.9
4"	100	7.6	194	3.1	79	0.63	16	8	0.88	22	8.8	222	9.3	235	RF/RTJ	23.5	10.8
6"	150	10.5	267	5.4	137	0.75	19.1	12	1	25	12	305	12.8	324	RF/RTJ	67.6	30.4
8"	200	12.6	321	6.5	165	1	25.4	12	1.1	29	14.3	312	14.8	375	RF/RTJ	113.7	51.94
10"	250	15.8	400	8.4	213	1.1	28.7	16	1.3	32	17	432	17.5	445	RF/RTJ	205.8	93.1
12"	300	18	457	9	229	1.3	31.8	20	1.3	32	17.8	451	18.3	464	RF/RTJ	294	133.28
14"	350	19.4	492	10.8	273	1.4	35.1	20	1.4	35	20.3	514	20.8	527	RF/RTJ	421.4	191.1
16"	400	22.3	565	12	305	1.5	38.1	20	1.5	38	22.3	565	22.8	578	RF/RTJ	637	289.1
18"	450	24.1	613	14.3	362	1.6	41.4	20	1.6	41	25.3	641	25.8	654	RF/RTJ	833	378.3
20"	500	26.9	683	14.5	368	1.8	44.5	24	1.6	41	26	660	26.8	679	RF/RTJ	1102.5	499.8
24"	600	31.1	791	17.3	438	2.0	50.8	24	1.6	41	29.8	756	30.8	781	RF/RTJ	1715	778.1
26"	650	34.1	867	18	457	-	-	28	1.9	48	31.8	806	32.8	832	RF/RTJ	1911	867.3
28"	700	36	914	19	483	-	-	28	2	51	33.3	845	34.3	870	RF/RTJ	2254	1022.1
30"	750	38.3	972	19.9	505	2.4	60.5	28	2	51	34.3	870	35.3	895	RF/RTJ	2793	1267.1
32"	800	40.3	1022	21	533	-	-	28	2.3	57	36.3	921	37.3	946	RF/RTJ	3136	1423
36"	900	44.5	1130	25	635	2.8	70.4	28	2.5	64	41.3	1048	42.5	1080	RF/RTJ	4606	2089.4
40"	1000	45.5	1156	26	660	-	-	32	2.3	57	44.5	1130	-	-	RF	5096	2311.8
42"	1050	48	1219	27.6	701	-	-	28	2.5	64	47.3	1200	-	-	RF	5880	2667.6

Class 900

Size		A		B		t		NO.	Stud Details				End Facing	Weight			
NPS	DN	in	mm	in	mm	in	mm		Diameter	RF Stud Length	RTJ Stud Length	RF Stud Length		RTJ Stud Length	lbs	kg	
									in	mm	in	mm		in	mm		
2"	50	5.6	143	2.8	70	0.75	19.1	8	0.88	22	8.5	216	8.7	222	RF/RTJ	11.3	2.9
3"	80	6.6	168	3.3	83	0.75	19.1	8	0.88	22	8.5	216	9	229	RF/RTJ	20.6	9.8
4"	100	8.1	206	4	102	0.84	21.3	8	1.1	29	10.3	260	10.8	273	RF/RTJ	42.1	19.6
6"	150	11.4	289	6.3	159	1	26.2	12	1.1	29	13.3	337	13.8	349	RF/RTJ	122.5	55.9
8"	200	14.1	359	8.1	206	1.3	31.8	12	1.4	35	16.3	413	16.8	425	RF/RTJ	269.5	122.5
10"	250	17.1	435	9.5	241	1.4	36.6	16	1.4	35	18.5	470	18.8	476	RF/RTJ	392	177.4
12"	300	19.6	498	11.5	292	1.7	42.2	20	1.4	35	20.8	527	21.3	540	RF/RTJ	441	199.9
14"	350	20.5	521	14	356	1.8	46	20	1.5	38	23.8	603	14.5	622	RF/RTJ	686	311.6
16"	400	22.6	575	15.1	384	2.1	52.3	20	1.6	41	25.5	648	26.3	667	RF/RTJ	931	422.4
18"	450	25.1	638	17.8	451	2.3	57.2	20	1.9	48	29.3	743	30	762	RF/RTJ	1372	622.3
20"	500	27.5	699	17.8	451	2.5	63.5	20	2	51	30	762	31	787	RF/RTJ	1617	733
24"	600	33.0	838	19.5	495	2.9	73.2	20	2.5	64	33.8	857	35	889	RF/RTJ	2278.5	1033.9

Class 1500

Size		A		B		t		NO.	Stud Details				End Facing	Weight			
NPS	DN	in	mm	in	mm	in	mm		Diameter	RF Stud Length	RTJ Stud Length	RF Stud Length		RTJ Stud Length	lbs	kg	
									in	mm	in	mm		in	mm		
2"	50	5.6	143	2.8	70	0.75	19.1	8	0.88	22	8.5	216	8.8	222	RF/RTJ	11.3	4.9
3"	80	6.9	175	3.3	83	0.94	23.9	8	1.1	29	10.3	260	10.5	267	RF/RTJ	22.5	9.8
4"	100	8.3	210	4	102	1.1	28.7	8	1.3	32	11.8	298	12	305	RF/RTJ	44.1	19.6
6"	150	11.1	283	6.3	159	1.5	38.1	12	1.4	35	16.5	419	17	432	RF/RTJ	122.5	55.9
8"	200	13.9	352	8.1	206	1.9	47.8	12	1.6	41	19.8	502	20.5	521	RF/RTJ	269.5	122.5
10"	250	17.1	435	9.8	248	2.3	57.2	12	1.9	48	23.3	591	23.8	603	RF/RTJ	421.4	191.1
12"	300	20.5	521	12	305	2.6	66.8	16	2	51	27	686	28	711	RF/RTJ	686	311.6
14"	350	22.8	578	14	356	2.8	69.9	16	2.3	57	30.3	768	31.5	800	RF/RTJ	906.5	411.6
16"	400	25.3	641	15.1	384	3.1	79.5	16	2.5	64	32.8	832	34.3	870	RF/RTJ	1274	578.2
18"	450	27.8	705	18.4	468	3.5	88.9	16	2.8	70	38	965	39.5	1003	RF/RTJ	1862	844.8
20"	500	29.8	756	21	533	3.9	98.6	16	3	76	42.3	1073	44	1118	RF/RTJ	2548	1155.4
24"	600	35.5	902	22	559	4.5	114.3	16	3.5	89	46.3	1175	48.5	1232	RF/RTJ	3650.5	1656.2

SDP SERIES DUAL PLATE CHECK VALVE

150LB 300LB

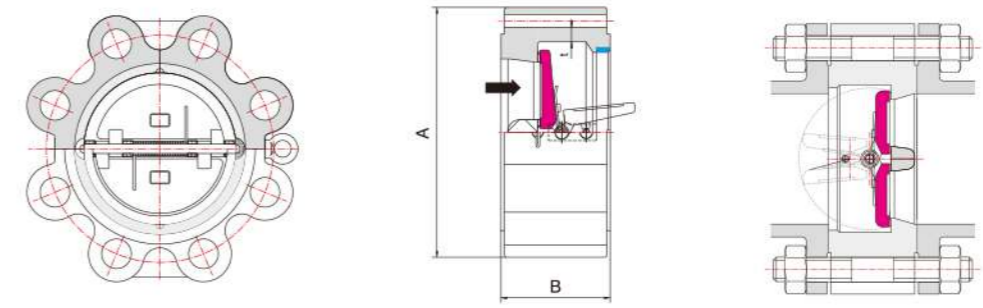

Class 150

Size		A		B		t		NO.	Stud Details				End Facing	Weight		
NPS	DN	in	mm	in	mm	in	mm		Diameter	RF Stud Length	RTJ Stud Length	RF Stud Length		RTJ Stud Length	lbs	kg
									in	mm	in	mm		in	mm	
2"	50	6	152	2.4	60	0.34	8.6	4	0.63	16	2.8	70	RF	8.8	3.9	
2 1/2"	65	7	178	2.6	67	0.38	9.7	4	0.63	16	2.8	70	RF	23.5	10.8	
3"	80	7.5	191	2.9	73	0.41	10.4	4	0.63	16	3	76	RF	17.6	7.8	
4"	100	9	229	2.9	73	0.44	11.2	8	0.63	16	3	76	RF	32.3	14.7	
5"	125	10	254	3.4	86	-	-	8	0.75	19	3.3	83	RF	51.9	23.5	
6"	150	11	279	3.9	98	0.47	11.9	8	0.75	19	3.3	83	RF	51.9	23.5	
8"	200	13.5	343	5	127	0.50	12.7	8	0.75	19	3.5	89	RF	127.4	57.8	
10"	250	16	406	5.8	146	0.56	14.2	12	0.88	22	3.8	95	RF	211.7	96	
12"	300	19	483	7.1	181	0.63	16	12	0.88	22	3.8	95	RF	264.6	120.5	
14"	350	21	533	7.3	184	0.66	16.8	12	1.0	25	4.3	108	RF	323.4	147	
16"	400	23.5	597	7.5	191	0.69	17.5	16	1.1	29	4.3	108	RF	411.6	187.2	
18"	450	25	635	8	203	0.72	18.3	16	1.1	29	4.8	121	RF	490	222.5	
20"	500	27.5	699	8.6	219	0.75	19.1	20	1.1	32	5	127	RF	637	289.1	
24"	600	32	813	8.8	222	0.81	20.6	20	1.3	32	5.5	140	RF	833	378.3	
26"	650	34.3	870	14	356	-	-	24	1.3	32	6.5	165	RF	1568	711.5	
28"	700	36.5	927	15	381	-	-	28	1.3	32	6.5	165	RF	1862	844.8	
30"	750	38.8	984	12	305	0.91	23.1	28	1.3	32	6.8	171	RF	1666	756.6	
32"	800	41.8	1060	14	356	-	-	28	1.5	38	7.5	191	RF	2352	1067	
36"	900	46	1168	14.5	368	1	25.4	32	1.5	38	8	203	RF	2744	1244.6	
40"	1000	50.8	1289	17	432	-	-	36	1.5	38	8	203	RF	4018	1822.8	
42"	1050	53	1340	17	432	1.1	27.7	36	1.5	38	8.3	210	RF	4312	1956.1	
48"	1200	59.5	1511	20.6	524	1.2	30.2	44	1.5	38	8.8	222	RF	6468	2934.1	

Class 300

Size		A		B		t		NO.	Stud Details				End Facing	Weight		
NPS	DN	in	mm	in	mm	in	mm		Diameter	RF Stud Length	RTJ Stud Length	RF Stud Length		RTJ Stud Length	lbs	kg
									in	mm	in	mm		in	mm	
2"	50	6.5	165	2.4	60	0.38	9.7	8	0.63	16	2.8	70	RF	17.6	7.8	
2 1/2"	65	7.5	191	2.6	67	0.44	11.2	8	0.75	19	3.3	83	RF	25.5	11.8	
3"	80	8.3	210	2.9	73	0.47	11.9	8	0.75	19	3.5	89	RF	32.3	14.7	
4"	100	10	254	2.9	73	0.50	12.7	8	0.75	19	3.5	89	RF	53.9	24.5	
5"	125	11	27													

SDP SERIES DUAL PLATE CHECK VALVE

600LB 900LB 1500LB

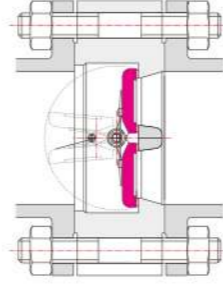
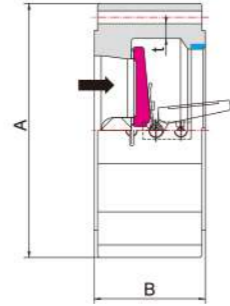
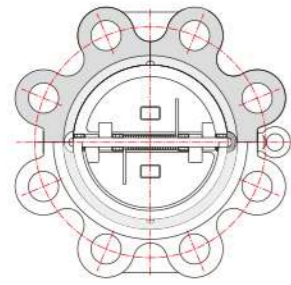

Class 600

Size		A		B		t		NO.	Stud Details			End Facing	Weight			
NPS	DN	in	mm	in	mm	in	mm		Diameter	RF Stud Length	RTJ Stud Length		lbs	kg		
2"	50	6.5	165	2.4	60	0.44	11.2	8	0.63	16	3.3	83	3.8	95	17.6	7.8
3"	80	8.3	210	2.9	73	0.50	12.7	8	0.75	19	3.8	95	4.3	108	32.3	14.7
4"	100	10.8	273	3.1	79	0.63	16	8	0.88	22	4.3	108	4.8	121	78.4	38.2
6"	150	14	356	5.4	137	0.75	19.1	12	1.0	25	5	127	5.5	140	168.6	76.4
8"	200	16.5	419	6.5	165	1	25.4	12	1.1	29	5.8	146	6	152	305.8	139.2
10"	250	20	508	8.4	213	1.1	28.7	16	1.3	32	6.3	159	6.8	171	504.7	229.3
12"	300	22	559	9	229	1.3	31.8	20	1.3	32	6.5	165	6.8	171	539	245
14"	350	23.8	603	10.8	273	1.4	35.1	20	1.4	35	6.8	171	7.3	184	784	355.7
16"	400	27	686	12	305	1.5	38.1	20	1.5	38	7.5	191	7.8	197	1127	511.6
18"	450	29.3	743	14.3	362	1.6	41.4	20	1.6	41	8	203	8.5	216	1519	688.9
20"	500	32	813	14.5	368	1.8	44.5	24	1.6	41	8.3	210	9	229	1862	844.8
24"	600	37	940	17.3	438	2	50.8	24	1.6	41	8.8	222	9.5	241	2940	1275
26"	650	40	1016	18	457	-	-	28	1.9	48	9.5	241	10.5	267	3332	1511.2
28"	700	42.3	1073	19	483	-	-	28	2	51	10	254	11	179	3920	1777.7
30"	750	44.5	1130	19.9	505	2.4	60.5	28	2	51	10.3	260	11.3	286	4606	2089.4
32"	800	47	1194	21	533	-	-	2a	2.3	57	11	279	12	305	5292	2400
36"	900	51.8	1314	25	635	2.8	70.4	28	2.5	64	11.8	298	13	330	7644	3467.2
40"	1000	52	1321	26	660	-	-	32	2.3	57	12.5	318	-	-	7938	3600.5
42"	1050	55.3	1403	27.6	701	3.2	80	28	2.5	64	13.5	343	-	-	9408	4267.9

Class 900

Size		A		B		t		NO.	Stud Details			End Facing	Weight			
NPS	DN	in	mm	in	mm	in	mm		Diameter	RF Stud Length	RTJ Stud Length		lbs	kg		
2"	50	8.5	216	2.8	70	0.75	19.1	8	0.9	22	4.3	108	4.8	121	36.3	16.7
3"	80	9.5	241	3.3	83	0.75	19.1	8	0.9	22	4	102	4.5	114	58.8	26.5
4"	100	11.5	292	4	102	0.84	21.3	8	1.1	29	5	127	5.5	140	93.1	42.1
6"	150	15	381	6.3	159	1.0	26.2	12	1.1	29	5.3	133	5.8	146	249.9	113.7
8"	200	18.5	470	8.1	207	1.3	31.8	12	1.4	35	6.3	159	6.8	171	470.4	213.6
10"	250	21.5	546	9.5	241	1.4	36.6	16	1.4	35	6.5	165	7	178	715.4	324.4
12"	300	24	610	11.5	292	1.7	42.2	20	1.4	35	6.8	171	7.3	184	833	378.3
14"	350	25.3	641	14	356	1.8	46	20	1.5	38	7.3	184	7.8	197	1225	555.7
16"	400	27.8	705	15.1	384	2.1	52.3	20	1.6	41	7.8	197	8.5	216	1617	733
18"	450	31	787	17.8	451	2.3	57.2	20	1.9	48	8.5	216	9.5	241	2450	1111.3
20"	500	33.8	857	17.8	451	2.5	63.5	20	2	51	9.3	235	10	254	2842	1288.7
24"	600	41	1041	19.5	495	2.9	73.2	20	2.5	64	11	279	12	305	4312	1956.1

Class 1500

Size		A		B		t		NO.	Stud Details			End Facing	Weight			
NPS	DN	in	mm	in	mm	in	mm		Diameter	RF Stud Length	RTJ Stud Length		lbs	kg		
2"	50	8.5	216	2.8	70	0.8	19.1	8	0.9	22	4.3	108	4.8	121	34.3	15.7
3"	80	10.5	267	3.3	83	0.9	23.9	8	1.1	29	5.3	133	5.8	146	69.6	31.4
4"	100	12.3	311	4	102	1.1	28.7	8	1.3	32	6	152	6.3	159	147	66.6
6"	150	15.5	394	6.3	159	1.5	38.1	12	1.4	35	7.3	184	7.8	197	259.7	117.6
8"	200	19	483	8.1	207	1.9	47.8	12	1.6	41	8.3	210	9	229	24.5	278.3
10"	250	23	584	9.8	248	2.3	57.2	12	1.9	48	9.5	241	10.3	260	782	354.8
12"	300	26.5	673	12	305	2.6	66.8	16	2	51	10.5	267	11.5	292	1372	622.3
14"	350	29.5	749	14	356	2.8	69.9	16	2.3	57	11.5	292	12.8	324	2352	1067.2
16"	400	32.5	826	15.1	384	3.1	79.5	16	2.5	64	12.8	324	14	356	2450	1111.3
18"	450	36	914	18.4	468	3.5	88.9	16	2.8	70	14	356	15.3	387	3822	1733.6
20"	500	38.8	984	21	533	3.9	98.6	16	3	76	15.3	387	16.8	425	5684	2578.4
24"	600	40	1168	22	559	4.5	114.3	16	3.5	89	17.5	445	19.3	489	7056	3200.7

SDP SERIES DUAL PLATE CHECK VALVE

150LB 300LB 600LB 900LB

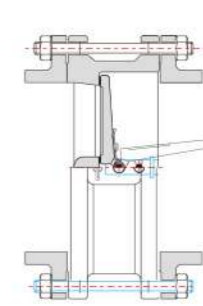
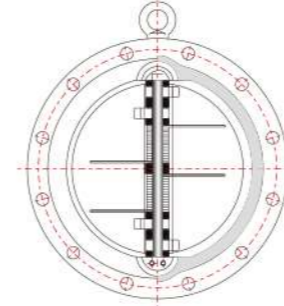

Class 150

Size		A		B		t		NO.	Stud Details			End Facing	Weight		
NPS	DN	in	mm	in	mm	in	mm		Diameter	RF Stud Length	RTJ Stud Length		lbs	kg	
12"	300	19	483	7.1	181	0.63	16	12	0.9	22	4.8	121	RF	273.4	124.5
14"	350	21	533	7.3	184	0.66	16.8	12	1	25	5.3	133	RF	312.6	142.1
16"	400	23.5	597	7.5	191	0.69	17.5	16	1.1	29	5.5	140	RF	379.3	172.5
18"	450	25	635	8	203	0.72	18.3	16	1.1	29	6	152	RF	450.8	204.8
20"	500	27.5	699	8.6	219	0.75	19.1	20	1.3	32	6.3	159	RF	588	266.6
24"	600	32	813	8.8	222	0.81	20.6	20	1.3	32	7	178	RF	844.8	383.2
26"	650	34.3	870	14	356	-	-	24	1.3	32	8.8	222	RF	1470	666.4
28"	700	36.5	927	15	381	-	-	28	1.3	32	9	229	RF	1666	755.6
30"	750	38.8	984	12	305	0.91	23.1	28	1.3	32	9.3	235	RF	1715	778.1
32"	800	41.8	1060	14	356	-	-	28	1.5	38	10.5	267	RF	2254	1022.1
36"	900	46	1168	14.5	368	1	25.4	32	1.5	38	11.3	286	RF	2474.5	1122.1
40"	1000	50.8	1289	17	432	-	-	36	1.5	38	11.3	286	RF	3822	1733.6
42"	1050	53	1340	17	432	1.1	27.7	36	1.5	38	11.8	298	RF	4135.6	1875.7
48"	1200	59.5	1511	20.6	524	1.2	30.2	44	1.5	38	12.5	318	RF	5782	2622.5

Class 300

Size		A		B		t		NO.	Stud Details			End Facing	Weight		
NPS	DN	in	mm	in	mm	in	mm		Diameter	RF Stud Length	RTJ Stud Length		lbs	kg	
12"	300	20.5	521	7.1	181	0.81	20.6	16	1.1	29	6.8	171	RF	329.3	149
14"	350	23	584	8.8	222	0.88	22.4	20	1.1	29	7	178	RF	422.4	192.1
16"	400	25.5	648	9.1	232	0.94	23.9	20	1.3	32	7.5	191	RF	661.5	299.9
18"	450	28	711	10.4	264	1.0	25.4	24	1.3	32	7.8	197	RF	833	378.3
20"	500	30.5	775	11.5	292	1.1	26.9	24	1.3	32	8.3	210	RF	1056.4	479.2
24"	600	36	914	12.5	318	1.2	30.2	24	1.5	38	9.3	235	RF	1925.7	873.2
26"	650	38.3	972	14	356	-	-	28	1.6	41	10.5	267	RF	2156	978
28"	700	40.8	1035	15	381	-	-	28	1.6	41	11	279	RF	2548	1155.4
30"	750	43	1092	14.5	368	1.4	35.1	2a	1.7	44	11.8	298	RF	3454.5	1567
32"	800	45.2	1149	16	406	-	-	28	1.9	48	12.8	324	RF	3234	1467.1
36"	900	48.7	1238	19	483	1.6	39.9	32	2	51	13.3	337	RF	4606	2089.4
40"	1000	50	1270	21.5	546	-	-	32	1.6	41	13.3	337	RF	4802	2178.5
42"	1050	50.8	1289	22.4	568	1.8	44.7	32	1.6	41	13.8	349	RF	4900	2222.6
48"	1200	57.8	1467	24.8	629	1.9	49.5	32	1.9	48	15.3	387	RF	7252	3289.9

Class 600

Size		A		B		t		NO.	Stud Details			End Facing	Weight			
NPS	DN	in	mm	in	mm	in	mm		Diameter	RF Stud Length	RTJ Stud Length		lbs	kg		
12"	300	22	559	9	229	1.3	31.8	20	1.3	32	8.5	216	9	229	539	244
14"	350	23.8	603	10.8	273	1.4	35.1	20								



SUYAN VALVE

Forged Steel Check Valve



SuYan forged steel check valve are manufactured in accordance with API602, ISO15761 and ASME B16.34 and tested to API598. And forged steel check valve are available in three bonnet designs: bolted bonnet, welded bonnet and pressure seal bonnet.

Design Feature:

- Full port or Reduced port
- Bolted cover/Welded cover/Pressure seal cover
- Socket welded (SW) ends to ASME B16.11
- Screwed ends (NPT) to ASME B1.20.1
- Flanges (RF/RTJ) according to ASME B16.5
- Integral flange or welded flange
- BW ends to ASME B16.25
- Cryogenic forged steel check valve (optional)
- The spherical piston check valve (optional)
- Y-Pattern piston check valve

PISTON

CHECK VALVE

SW/NPT END

800LB 900LB 1500LB



SUYAN VALVE

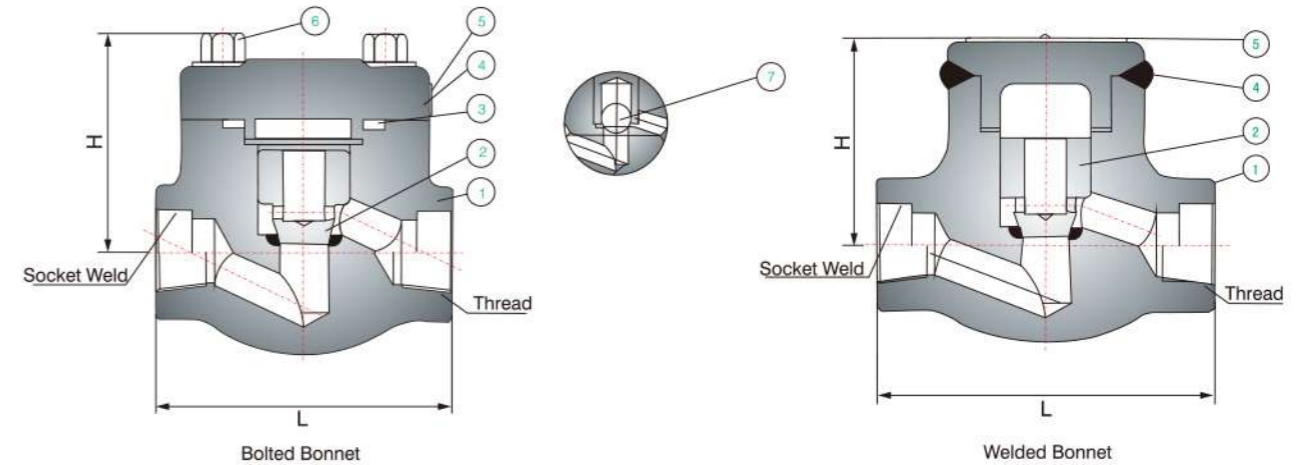

Material List

No.	Part Name	Cast Steel	Alloy Steel	Stainless Steel	
1	Body	A105N+STL 6/cr13	A182 F22	A182 F304(L)	A182 F316(L)
2	Piston Disc	A182 F6a	A182 F304	A182 F304(L)	A182 F316(L)
3	Gasket	SPW SS304+Graphite	SPW SS304+Graphite	SPW SS304(L)+Graphite	SPW SS316(L)+Graphite
4	Bonnet	A105N	A182 F22	A182 F304(L)	A276 F316(L)
5	Nameplate	SS304	SS304	SS304	SS304
6	Bolt	A193 B7	F193 B16	A193 B8(M)	A193 B8(M)
7	Ball	A182 F6a	A182 F304	A182 F304(L)	A182 F316(L)

Dimension and Weight

NPS		Conv.	3/8"	1/2"	3/4"	1"	1 1/4"	1 1/2"	2"	2 1/2"	
			Full	7/8"	3/8"	1/2"	3/4"	1"	1 1/4"	1 1/2"	2"
800LB	L	mm	76	76	92	106	120	148	172	220	
	H	mm	50	50	60	70	80	85	100	120	
	Weight	Bolted	kg	1.4	1.2	1.5	3.1	3.9	5.6	8.9	12.5
		Welded	kg	1.1	1.0	1.2	2.9	3.3	4.9	8.1	10.9
900LB	L	mm	111	111	111	120	152	172	220		
	H	mm	75	75	75	100	110	120	140		
	Weight	Bolted	kg	1.6	3.4	3.3	5.5	6.0	9.2	12.9	
		Welded	kg	1.3	3.2	3.1	4.8	5.4	8.5	11.2	
1500LB	L	mm	111	111	111	120	152	172	220		
	H	mm	75	75	75	100	110	120	140		
	Weight	Bolted	kg	1.6	3.4	3.3	5.5	6.0	9.2	12.9	
		Welded	kg	1.3	3.2	3.1	4.8	5.4	8.5	11.2	

CHECK VALVE

RF/RTJ/BW END

150LB~1500LB



SUYAN VALVE

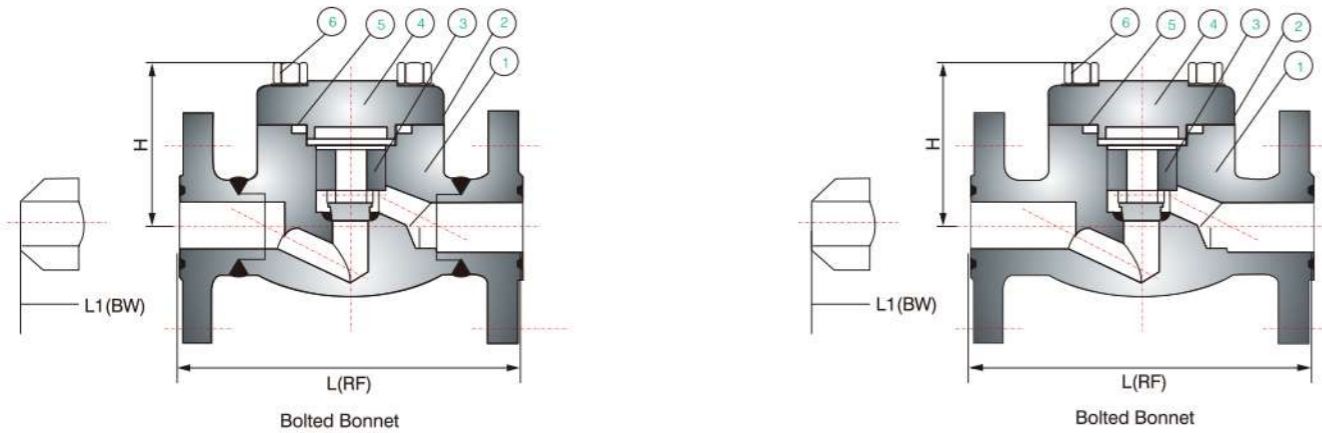

Material List

No.	Part Name	Cast Steel	Alloy Steel	Stainless Steel	
1	Body	A105N+STL.6	A182 F22+STL.6	A182 F304(L)+STL.6	A182 F316(L)+STL.6
2	Nameplate	SS304	SS304	SS304	SS304
3	Piston Disc	A182 F6a	A182 F304	A182 F304(L)	A182 F316(L)
4	Bonnet	A105N	A182 F22	A182 F304(L)	A182 F316(L)
5	Gasket	SPW. SS304+Graphite	SPW. SS304+Graphite	SPW. SS304(L)+Graphite	SPW. SS316(L)+Graphite
6	Bolt	A193 B7	A193 B16	A193 B8	A193 B8M

Dimension and Weights

NPS			1/2	3/4	1	1 1/4	1 1/2	2	
	150LB	L	RF	mm	108	117	127	140	165
	L1	BW	mm	108	117	127	140	165	203
	H		mm	61	61	79	95	103	118
	Weight	RF	kg	2.56	3.37	4.37	8.17	8.94	12.64
		BW	kg	1.70	1.90	2.10	5.12	5.50	7.89
300LB	L	RF	mm	152	178	203	216	229	267
	L1	BW	mm	152	178	216	229	241	267
	H		mm	61	61	79	95	103	118
	Weight	RF	kg	2.73	3.65	4.74	8.77	9.60	13.70
		BW	kg	1.90	2.10	3.00	5.12	6.60	7.85
600LB	L	RF	mm	165	190	216	229	241	292
	L1	BW	mm	165	190	216	229	241	292
	H		mm	61	61	79	95	103	118
	Weight	RF	kg	3.00	4.00	5.83	9.47	10.10	15.60
		BW	kg	2.00	3.12	4.25	7.25	8.56	13.60
900LB	L	RTJ	mm	216	229	254	279	305	371
	L1	BW	mm	216	229	254	279	305	368
	H		mm	79	79	95	104	120	139
	Weight	RTJ	kg	8.5	10.5	15.7	20.8	27.2	33.0
		BW	kg	6.4	8.0	13.2	17.8	24.2	29.7
1500LB	L	RTJ	mm	216	229	254	279	305	371
	L1	BW	mm	216	229	254	279	305	368
	H		mm	79	79	95	104	120	139
	Weight	RTJ	kg	8.5	10.5	15.7	20.8	27.2	33.0
		BW	kg	6.4	8.0	13.2	17.8	24.2	29.7

CHECK VALVE

RF/RTJ/BW END

800LB 900LB 1500LB 2500LB



SUYAN VALVE

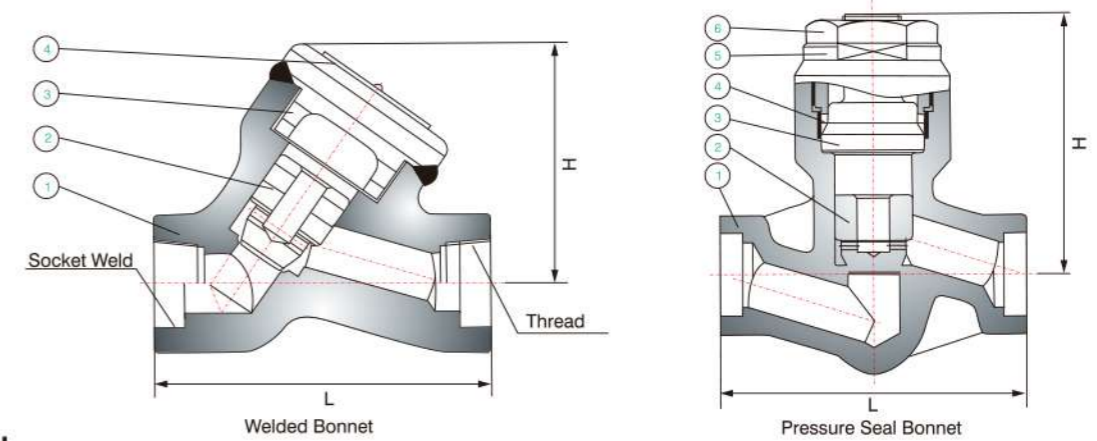

Y PATTERN Material List

No.	Part Name	Cast Steel	Alloy Steel	Stainless Steel	
1	Body	A105N+STL.6	A182 F22+STL.6	A182 F304(L)+STL.6	A182 F316(L)+STL.6
2	Piston Disc	A182 F6a	A182 F304	A182 F304(L)	A182 F316(L)
3	Bonnet	A105N	A182 F22	A182 F304(L)	A182 F316(L)
4	Nameplate	Stainless Steel	Stainless Steel	Stainless Steel	Stainless Steel

Dimension and Weight

NPS			3/8"	1/2"	3/4"	1"	1 1/4"	1 1/2"	2"
		Conv.							
	Full		/	3/8"	1/2"	3/4"	1"	1 1/4"	1 1/2"
800LB	L	mm	98	98	98	120	120	140	170
	H	mm	85	85	95	105	115	120	135
	Weight	kg	3.1	3.0	3.7	6.5	8.5	8.0	10.9

PRESSURE SEAL Material List

No.	Part Name	Cast Steel	Alloy Steel	Stainless Steel	
1	Body	A105N+STL.6	A182 F22+STL.6	A182 F304(L)+STL.6	A182 F316(L)+STL.6
2	Piston Disc	A182 F6a	A182 F304	A182 F304(L)	A182 F316(L)
3	Sealing Seat	A182 F6a	A182 F304	A182 F304(L)	A182 F316(L)
4	Pressure Ring	A182 F6a	A182 F304	A182 F304(L)	A182 F316(L)
5	Retainion Nut	A105N	A182 F22	A182 F304(L)	A182 F316(L)
6	P.S.Lock Nut	A105N	A182 F22	A182 F304(L)	A182 F316(L)

Dimension and Weight

NPS			1/2"	3/4"	1"	1 1/4"	1 1/2"	2"
	900LB	L	mm	120	120	140	178	178
	H	mm	135	135	150	170	170	190
	Weight	kg	7.5	7.0	6.8	18.5	18.1	20.3
1500LB	L	mm	120	120	140	178	178	216
	H	mm	135	135	150	170	170	190
	Weight	kg	7.5	7.0	6.8	18.5	18.1	20.3
2500LB	L	mm	140	140	186	232	232	279
	H	mm	150	150	170	180	190	215
	Weight	kg	9.0	7.6	8.4	19.5	20.1	21.8

PRESSURE SEAL

RF/RTJ END

900LB~2500LB



SUYAN VALVE

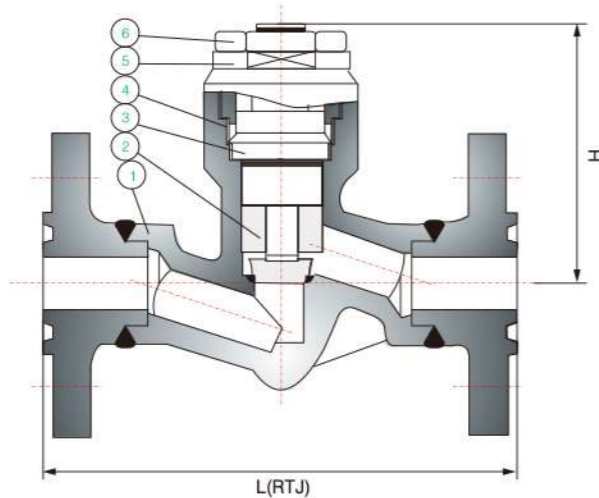

Pressure Seal Bonnet

Material List

No.	Part Name	Cast Steel	Alloy Steel	Stainless Steel	
1	Body	A105N+STL.6	A182 F22+STL.6	A182 F304(L)+STL.6	A182 F316(L)+STL.6
2	Piston Disc	A182 F6a	A182 F304	A182 F304(L)	A182 F316
3	Pressure Seat	A182 F6a	A182 F304	A182 F304(L)	A182 F316
4	Pressure Ring	A182 F6a	A182 F304	A182 F304(L)	A182 F316
5	Retaining Nut	A105N	A182 F22	A182 F304(L)	A182 F316(L)
6	P.S.Lock Nut	A105N	A182 F22	A182 F304(L)	A182 F316(L)

Dimension and Weight

	NPS		mm	1/2"	3/4"	1"	1 1/4"	1 1/2"	2"
	L	RTJ							
900LB	L	RTJ	mm	216	229	254	279	305	371
	H		mm	117	117	117	152	152	195
	Weight		kg	10.5	11.9	13.9	19.9	26.9	32.5
1500LB	L	RTJ	mm	216	229	254	279	305	371
	H		mm	117	117	117	152	152	195
	Weight		kg	10.5	11.9	13.9	19.9	26.9	32.5
2500LB	L	RTJ	mm	264	273	308	349	384	454
	H		mm	117	117	117	152	152	195
	Weight		kg	12.6	14.9	16.5	24.8	30.0	35.0

CHECK VALVE

SW/NPT END

800LB 900LB 1500LB



SUYAN VALVE

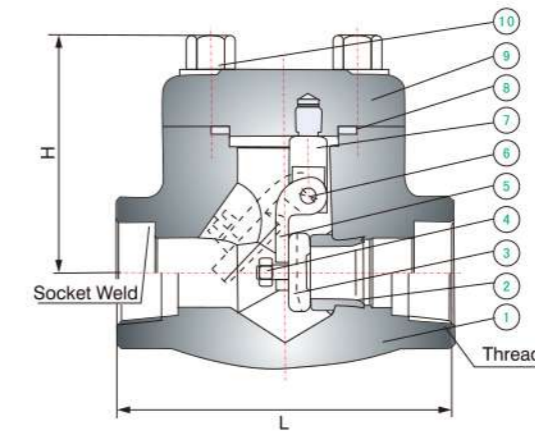

Bolted Bonnet

Material List

No.	Part Name	Cast Steel	Alloy Steel	Stainless Steel	
1	Body	A105N	A182 F22	A182 F304(L)	A182 F316(L)
2	Seat	A182 F6a+STL.6	A182 F304	A182 F304(L)	A182 F316(L)
3	Swing Disc	A182 F6a	A182 F304	A182 F304(L)	A182 F316(L)
4	Nut	A194 2H	A194 4	A194 8	A194 8M
5	Hinge	A182 F6a	A182 F304	A182 F304 L	A182 F306(L)
6	Pin	A276 410	A276 304	A276 304	A276 316
7	Ponlevis	A182 F6a	A182 F304	A182 F304L	A182 F316(L)
8	Gasket	SPW. SS304+Graphite	SPW. SS304+Graphite	SPW. SS304(L)+Graphite	SPW. SS316(L)+Graphite
9	Bonnet	A105N	A182 F22	A182 F304(L)	A182 F316(L)
10	Bolt	A193 B7	A193 B16	A193 B8M	A193 B8M

Dimension and Weight

	NPS		mm	3/8"	1/2"	3/4"	1"	1 1/4"	1 1/2"	2"
	L	H								
800LB	L	H	mm	79	79	92	106	120	114	144
			mm	60	60	65	75	90	95	115
	Weight		kg	1.1	1.0	1.9	3.9	4.5	6.7	9.6
900LB	L	H	mm	111	111	111	120	120	140	170
			mm	75	75	80	90	110	120	135
	Weight		kg	3.1	3.0	3.6	4.3	6.1	8.8	12.6
1500LB	L	H	mm	111	111	111	120	120	140	170
			mm	75	75	80	90	110	120	135
	Weight		kg	3.1	3.0	3.6	4.3	6.1	8.8	12.6



SUYAN VALVE

SUYAN
GROUP

Cast steel Pressure Seal Valve



Special designed for high temperature and high pressure application;
Tight and Reliable Sealing;
Compact structure;
Minimum maintenance.

Stellite faced flexible "H" type wedge prevents sticking due to temperature changes and pipe line stresses.
Seal rings are stellite faced and securely welded in place.
The bonnet joint remains tight under all operating conditions as the sealing pressure is always many times greater than the pressure of the fluid in the line, there by eliminating leakage. The higher the internal pressure, the greater the sealing pressure.

GAPS Series

SuYan GAPS series Gate Valve are manufactured in accordance with API 600, ASME B16.34 specification and tested to API 598, and this series valves are of API 591 certified, and API 624, ISO15848, TA Luft Certified. To ensure casting integrity, all pressure contain casting are from SuYan own foundry.

Flanged Ends / Butt Welding Ends Pressure Seal Bonnet OS&Y

End to end dimensions and wall thickness conform to ANSI and API specification;
Anti blow-out stem design;
Hard facing seat design;
Gear operator can be furnished upon request;
Optional by pass design;
Optional double packing with lantern ring;
Vacuum PWHT applied for Cr-Mo pup piece welding.
Stellite faced flexible "H" type wedge prevents sticking due to temperature changes and pipe line stresses.
Stellite back seat area provides accurate guiding of stem.



Part	Standard	Stainless Steel	Low Temperature	High Temperature	Sour Service
Body	ASTM A216 GR.WCB	ASTM A351 GR.CF8M	ASTM A352 GR.LCC	ASTM A217 GR.WC9	ASTM A216 GR.WCB
Seat Ring	ASTM A105N + STL.6	ASTM A182 GR.F316+STL.6	ASTM A350 GR.LF2+STL.6	ASTM A182 F22 + STL.6	ASTM A105N + STL.6
Flexible Wedge	ASTM A216 GR.WCB + Cr13	ASTM A351 GR.CF8M	ASTM A352 GR.LCC	ASTM A217 GR.WC9 + Cr13	ASTM A216 GR.WCB + Cr13
Stem	ASTM A182 GR. F6a	ASTM A182 GR.F316	ASTM A182 GR.F316	ASTM A182 GR. F6a	ASTM A182 GR. F6a-NC
Stuffing Box	ASTM A105N	ASTM A182 F316	ASTM A350 LF2	ASTM A182 F22	ASTM A105N
*Sealing Ring	SS304 + Graphite / SS316L	SS316 + Graphite / SS316L	SS316 + Graphite / SS316L	SS304 + Graphite / SS316L	SS304 + Graphite / SS316L
Pressure Ring	ASTM A276 Type 410	ASTM A276 Type 316	ASTM A276 Type 316	ASTM A276 Type 410	ASTM A276 Type 410-NC
Segment Ring	ASTM A182 GR. F6a	ASTM A182 GR.F316	ASTM A182 GR.F316	ASTM A182 GR. F6a	ASTM A182 GR. F6a-NC
Support Plate	ASTM A216 GR.WCB	ASTM A351 GR.CF8M	ASTM A352 GR.LCC	ASTM A217 GR.WC9	ASTM A216 GR.WCB
Packing	Graphite Ring	Graphite Ring	Graphite Ring	Graphite Ring	Graphite Ring
Box-Plate Bolt	ASTM A193 GR.B7	ASTM A193 GR.B8	ASTM A320 GR.L7	ASTM A193 GR.B16	ASTM A193 GR.B7M
Box-Plate Nut	ASTM A194 GR.2H	ASTM A194 GR.8	ASTM A194 GR.7	ASTM A194 GR.4	ASTM A194 GR.2HM
Bolt	ASTM A193 GR.B7	ASTM A193 GR.B8	ASTM A320 GR.L7	ASTM A193 GR.B16	ASTM A193 GR.B7M
Nut	ASTM A194 GR.2H	ASTM A194 GR.8	ASTM A194 GR.7	ASTM A194 GR.4	ASTM A194 GR.2HM
Gland Flange Seat	ASTM A105N	ASTM A182 GR.F316	ASTM A350 GR.LF2	ASTM A182 F22	ASTM A105N
Gland	ASTM A276 Type 410	ASTM A276 Type 316	ASTM A276 Type 316	ASTM A276 Type 410	ASTM A276 Type 410-NC
Gland Flange	ASTM A216 GR.WCB	ASTM A351 GR.CF8M	ASTM A352 GR.LCC	ASTM A217 GR.WC9	ASTM A216 GR.WCB
Gland Eye Bolt	ASTM A193 GR.B7	ASTM A193 GR.B8	ASTM A320 GR.L7	ASTM A193 GR.B16	ASTM A193 GR.B7M
Gland Eyebolt Nut	ASTM A194 GR.2H	ASTM A194 GR.8	ASTM A194 GR.7	ASTM A194 GR.4	ASTM A194 GR.2HM
Yoke	ASTM A216 GR.WCB	ASTM A351 GR.CF8M	ASTM A352 GR.LCC	ASTM A217 GR.WC9	ASTM A216 GR.WCB
Stem Nut	ASTM A439 D-2	ASTM A439 D-2	ASTM A439 D-2	ASTM A439 D-2	ASTM A439 D-2
Grease Nipple	Carbon Steel	Stainless Steel	Stainless Steel	Stainless Steel	Stainless Steel
Retaining Nut	Carbon Steel	Stainless Steel	Stainless Steel	Carbon Steel	Carbon Steel
Handwheel	Malleable Iron	Malleable Iron	Malleable Iron	Malleable Iron	Malleable Iron
Screw	Carbon Steel	Stainless Steel	Stainless Steel	Carbon Steel	Carbon Steel
Handwheel Nut	Carbon Steel	Stainless Steel	Stainless Steel	Carbon Steel	Carbon Steel

* Sealing Ring: 4" and below 4" is SS + Graphite
above 4" is SS

CAST STEEL

GAPS SERIES PRESSURE SEAL GATE VALVE

600LB 900LB

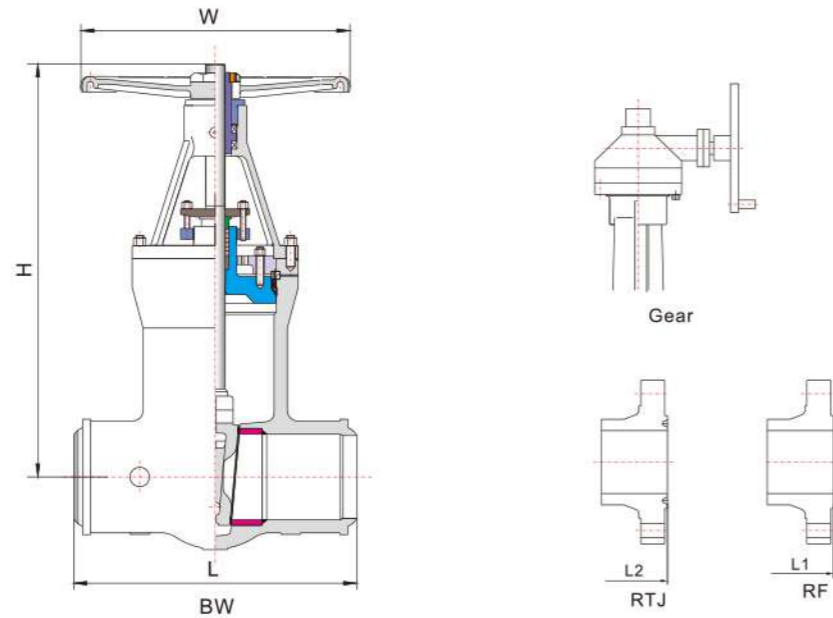

Class 600

NPS	in	2"	2-1/2"	3"	4"	5"	6"	8"	10"	12"	14"	16"	18"	20"	24"	26"	28"	30"
DN	mm	50	65	80	100	125	150	200	250	300	350	400	450	500	600	650	700	750
L(BW)	in	7	8.5	10	12	15	18	23	28	32	35	39	43	47	55	/	/	/
	mm	177.8	215.9	254	304.8	381	457.2	584.2	711.2	812.8	889	991	1092	1194	1397	/	/	/
L1(RF)	in	12	13	14	17	20	22	26	31	33	35	39	43	47	55	57	61	65
	mm	295	333	359	435	511	562	663	790	841	892	994	1095	1200	1407	1461	1562	1664
L2(RTJ)	in	12	13	14	17	20	22	26	31	33	35	39	43	47	55	58	62	66
	mm	295	333	359	435	511	562	663	790	841	892	994	1095	1200	1407	1461	1562	1664
W	in	7.9	9.8	9.8	13.8	15.7	17.7	21.3*	21.3*	24*	24*	24*	24*	24*	24*	32*	32*	39.4*
	mm	200	250	250	350	400	450	540*	540*	610*	610*	610*	610*	610*	610*	800*	800*	1000*
H	in	23.2	24.8	26.3	36.0	39.4	42.5	49.9	59.5	70.5	73.1	85.1	88.6	97.3	118.1	128.0	137.9	149.0
	mm	589.3	629.9	668.0	914.4	1000.8	1079.5	1267.5	1511.3	1790.7	1856.7	2161.5	2250.4	2471.4	2999.7	3251.2	3502.7	3784.6
WT(RF)	kg	70	95	100	149	208	245	320	430	515	670	905	1150	1445	2080	2445	2895	3250
WT(BW)	kg	62	80	84	115	150	171	215	268	318	435	570	720	890	1285	1510	1750	2010

Class 900

NPS	in	2"	2-1/2"	3"	4"	6"	8"	10"	12"	14"	16"	18"	20"	24"	26"	28"	30"
DN	mm	50	65	80	100	150	200	250	300	350	400	450	500	600	650	700	750
L(BW)	in	8.5	10	12	14	20	26	31	36	39	43	48	52	61	65	68	72
	mm	215.9	254	304.8	355.6	508	660.4	787.4	914.4	990.6	1092.2	1219.2	1320.8	1549.4	1651	1727.2	1816.1
L1(RF)	in	14.5	16.5	15	18	24	29	33	38	40.5	44.5	48	52	/	/	/	/
	mm	368.3	419.1	381	457.2	609.6	736.6	838.2	965.2	1028.7	1130.3	1219.2	1320.8	1549.4	/	/	/
L2(RTJ)	in	14.6	16.6	15.1	18.1	24.1	29.1	33.1	38.1	40.9	44.9	48.5	52.5	61.8	/	/	/
	mm	370.8	421.6	383.5	459.7	612.1	739.1	840.7	967.7	1038.9	1140.5	1231.9	1333.5	1569.7	/	/	/
W	in	10	10	12	14	20	24*	24*	24*	32*	32*	32*	32*	39.4*	39.4*	39.4*	39.4*
	mm	254	254	305	356	508	610*	610*	610*	610*	610*	810*	810*	1000*	1000*	1000*	1000*
H	in	23	25	30	34	40	50	61	70	80	89	97.3	108.3	127.6	138.3	149	159.5
	mm	584.2	640	762	863.6	1016	1270	1549.4	1778	2032	2260.6	2471.4	2750.8	3241	3512.8	3784.6	4051.3
WT(RF)	kg	63	99	107	158	294	693	1008	1418	1785	2520	3820	4400	6770	/	/	/
WT(BW)	kg	42	67	70	108	194	520	772	1103	1470	2048	2730	3685	5430	6370	7385	8480

* Gear Operator

CAST STEEL

GAPS SERIES PRESSURE SEAL GATE VALVE

1500LB 2500LB

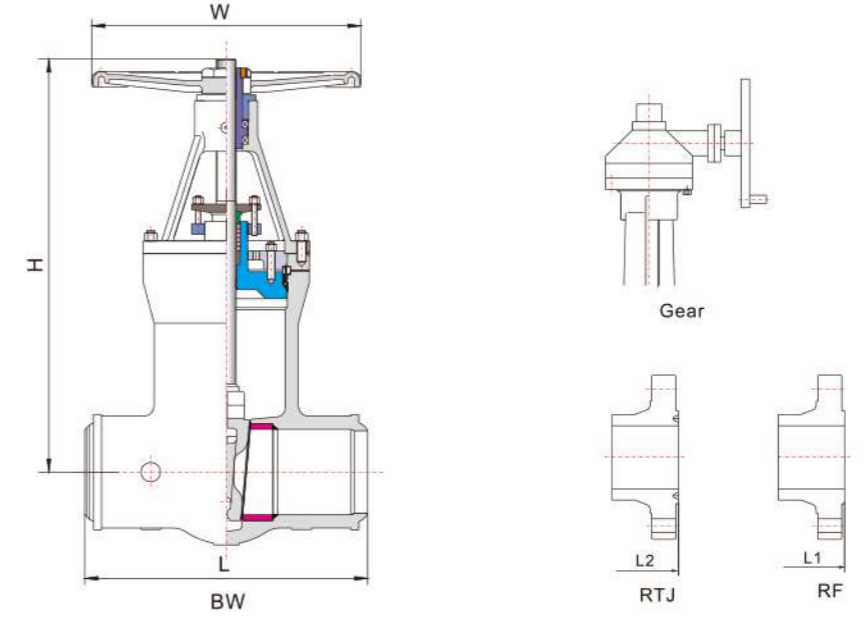

Class 1500

NPS	in	2"	2-1/2"	3"	4"	6"	8"	10"	12"	14"	16"	18"	20"	24"
DN	mm	50	65	80	100	150	200	250	300	350	400	450	500	600
L(BW)	in	8.5	10	12	16	22	28	34	39	42	47	53	58	66
	mm	215.9	254	304.8	406.4	558.8	711.2	863.6	990.6	1066.8	1193.8	1346.2	1473.2	1676.4
L1(RF)	in	14.5	16.5	18.5	21.5	27.8	32.8	39	44.5	49.5	54.5	60.5	65.5	76.5
	mm	368.3	419.1	469.9	546.1	706.12	833.12	990.6	1130.3	1257.3	1384.3	1536.7	1663.7	1943.1
L2(RTJ)	in	14.6	16.6	18.6	21.6	28	33.18	39.4	45.1	50.3	55.4	61.4	66.4	77.6
	mm	370.8	421.6	472.4	548.6	711.2	842.8	1000.8	1145.5	1277.6	1407.2	1559.6	1686.6	1971
W	in	10	12	14	20	24	18*	18*	24*	24*	24*	32*	39.4*	39.4*
	mm	254	305	356	508	610	460*	460*	610*	610*	610*	810*	1000*	1000*
H	in	23	30	30	34	39	53	58	74	87	92	111.1	122.1	148.3
	mm	584.2	762	762	863.6	990.6	1346.2	1473.2	1879.6	2209.8	2336.8	2821.9	3101.3	3766.8
WT(RF)	kg	63	99	126	218	504	956	1481	2184	2741	3780	5960	7370	10610
WT(BW)	kg	42	67	87	150	367	718	1071	1523	1890	2888	4630	5720	8240

Class 2500

NPS	in	2"	2-1/2"	3"	4"	6"	8"	10"	12"	14"	16"	18"	20"	24"
DN	mm	50	65	80	100	150	200	250	300	350	400	450	500	600
L(BW)	in	11	13	14.5	18	24	30	36	41	44	49	55	61	68
	mm	279	330	368	457	610	762	914	1041	1118	1245	1397	1549	1727
L1(RF)	in	17.8	20	22.8	26.5	36	40.3	50	56	/	/	/	/	/
	mm	451	508	579	673	914	1024	1270	1422	/	/	/	/	/
L2(RTJ)	in	17.9	20.3	23.0	26.9	36.5	40.8	50.9	56.9	/	/	/	/	/
	mm	454	514	584	683	927	1038	1292	1445	/	/	/	/	/
W	in	14	18	18	20	24*	24*	24*	24*	24*	24*	32*	32*	39.4*
	mm	356	457	457	508	610*	610*	610*	610*	610*	610*	810*	810*	1000*
H	in	23	30	30	34	44	55	69	74	94	97.3	116.1	128.8	153.6
	mm	584	762	762	864	1118	1397	1753	1880	2388	2471	2949	3272	3901
WT(RF)	kg	89	142	173	346	851	1386	2493	3091	/	/	/	/	/
WT(BW)	kg	53	95	100	200	488	850	1680	2330	3400	4200	5000	6170	8880

* Gear Operator

GLPS Series

SuYan GLPS series pressure seal globe Valve are manufactured in accordance with BS1873, ASME B16.34 specification and tested to API 598, and this series valves are of API 591 certified, and API624, ISO15848, TA Luft Certified. To ensure casting integrity, all pressure contain casting are from SuYan own foundry.

Flanged Ends / Butt Welding Ends Pressure Seal Bonnet OS&Y

End to end dimensions and wall thickness conform to ANSI and API specification;
Anti blow-out stem design;
Hard facing seat design;
Gear operator can be furnished upon request;
Optional by pass design;
Optional double packing with lantern ring;
Vacuum PWHT applied for Cr-Mo pup piece welding
Stellited back seat area provides accurate guiding of stem.



Part	Standard	Stainless Steel	Low Temperature	High Temperature	Sour Service
Body	ASTM A216 WCB	ASTM A351 CF8M	ASTM A352 LCC	ASTM A217 WC9	ASTM A216 WCB
Disc	ASTM A105N+STL.6	ASTM A182 F316+STL.6	ASTM A350-LF2+STL.6	ASTM A182 F22+STL.6	ASTM A105N+STL.6
Stem	ASTM A182 F6a	ASTM A182 F316	ASTM A182 F304	ASTM A182 F6a	ASTM A182 F6a(NACE)
Stuffing Box	ASTM A182 F6a	ASTM A182 F316	ASTM A182 F304	ASTM A182 F6a	ASTM A182 F6a(NACE)
*Sealing Ring	SS304 + Graphite / SS316L	SS316 + Graphite / SS316L	SS316 + Graphite / SS316L	SS304 + Graphite / SS316L	SS304 + Graphite / SS316L
Yoke	ASTM A216 WCB	ASTM A351 CF8M	ASTM A352 LCC	ASTM A217 WC9	ASTM A216 WCB
Lantern Ring	ASTM A182 F6a	ASTM A182 F316	ASTM A182 F304	ASTM A182 F6a	ASTM A182 F6a(NACE)
Packing	Graphite	Graphite	Graphite	Graphite	Graphite
Gland	ASTM A276 410	ASTM A276 316	ASTM A276 304	ASTM A276 410	ASTM A276 410
Gland Flang	ASTM A216 WCB	ASTM A351 CF8M	ASTM A352 LCC	ASTM A217 WC9	ASTM A216 WCB
Eye Bolt	ASTM A193 B7	ASTM A193 B8	ASTM A320 L7	ASTM A193 B16	ASTM A193 B7M
Nut	ASTM A193 2H	ASTM A193 8	ASTM A193 7	ASTM A193 4	ASTM A193 2HM
Stem Nut	ASTM A439 GR D-2	ASTM A439 GR D-2	ASTM A439 GR D-2	ASTM A439 GR D-2	ASTM A439 GR D-2
Handwheel Cover	ASTM A29 Type 1025	ASTM A29 Type 1025	ASTM A29 Type 1025	ASTM A29 Type 1025	ASTM A29 Type 1025
Impactor Handwhee	Ductile iron	Ductile iron+Zn	Ductile iron	Ductile iron	Ductile iron
Impact Block	ASTM A29 Type 1045	ASTM A29 Type 1045	ASTM A29 Type 1045	ASTM A29 Type 1045	ASTM A29 Type 1045
Disc Nut	ASTM A276 410	ASTM A276 316	ASTM A276 304	ASTM A276 410	ASTM A276 410(NACE)

* Sealing Ring: 4" and below 4" is SS + Graphite
above 4" is SS

CAST STEEL

GLPS SERIES PRESSURE SEAL GLOBE VALVE



600LB 900LB

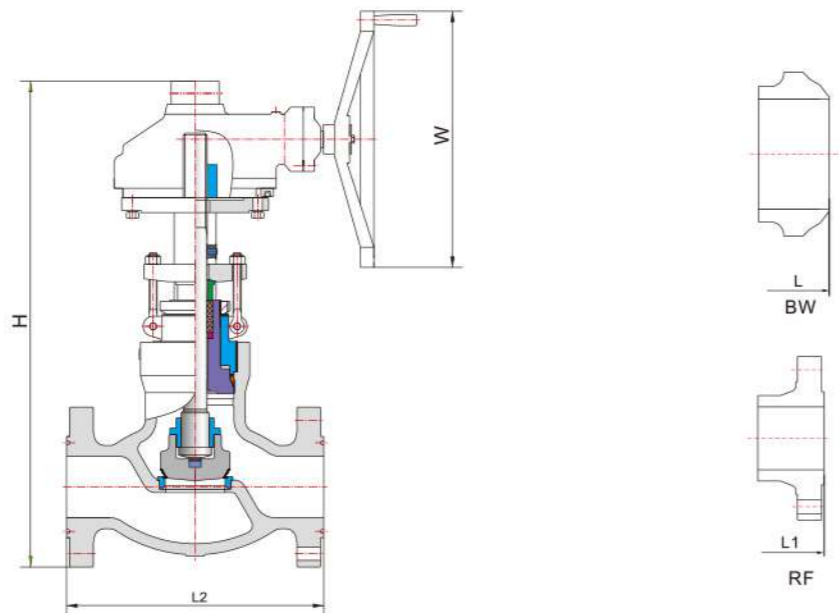

Class 600

NPS	in	2"	2-1/2"	3"	4"	5"	6"	8"	10"	12"	14"	16"
DN	mm	50	65	80	100	125	150	200	250	300	350	400
L(BW)	in	7	8.5	10	12	15	18	23	28	32	/	/
	mm	177.8	215.9	254	304.8	381	457.2	584.2	711.2	812.8	/	/
L1(RF)	in	11.5	13	14	17	20	22	26	31	33	35	39
	mm	292.1	330.2	355.6	431.8	508	558.8	660.4	787.4	838.2	889	991
L2(RTJ)	in	11.6	13.1	14.1	17.1	20.1	22.1	26.1	31.1	33.1	35.1	39.1
	mm	295.1	333.2	358.6	434.8	511	561.8	663.4	790.4	841.2	892	994
W	in	9.8	11.8	13.8	17.7	19.7	21.3*	21.3*	24*	24*	32*	32*
	mm	248.9	299.7	350.5	449.6	500	540*	540*	610*	610*	810*	810*
H	in	21.7	24.8	26.8	29.5	39.4	45.3	49.2	55.1	61	70.9	85.0
	mm	551.2	629.9	680.7	749.3	1000	1150.6	1249.7	1399.5	1549.4	1800	2150
WT(RF)	kg	45	55	85	135	190	305	620	1310	1900	2720	3150
WT(BW)	kg	35	45	60	95	150	230	540	1150	1720	2530	2900

Class 900

NPS	in	2"	2-1/2"	3"	4"	6"	8"	10"	12"	14"	16"
DN	mm	50	65	80	100	150	200	250	300	350	400
L(BW)	in	8.5	10	12	14	20	26	31	36	39	43
	mm	215.9	254	304.8	355.6	508	660.4	787.4	914.4	990.6	1092.2
L1(RF)	in	14.5	16.5	15	18	24	29	33	38	40.5	44.5
	mm	368	419	381	457	610	737	838	965	1029	1130
L2(RTJ)	in	14.6	16.6	15.1	18.1	24.1	29.1	33.1	38.1	40.9	44.9
	mm	371	422	384	460	613	740	841	968	1038	1140
W	in	14	14	18	20*	24*	24*	24*	32*	32*	39.4*
	mm	355.6	355.6	457.2	540*	610*	610*	610*	810*	810*	1000*
H	in	24.4	25.2	28.4	33.5	48.2	53.1	61	68.9	78.8	91
	mm	619.8	640.1	721.4	850.9	1224.3	1348.7	1549.4	1749.6	2000.3	2311.4
WT(RF)	kg	84	110	116	179	441	1050	1720	2300	3350	4000
WT(BW)	kg	58	74	84	137	378	945	1520	2050	3050	3600

* Gear Operator

CAST STEEL

GLPS SERIES PRESSURE SEAL GLOBE VALVE



1500LB 2500LB

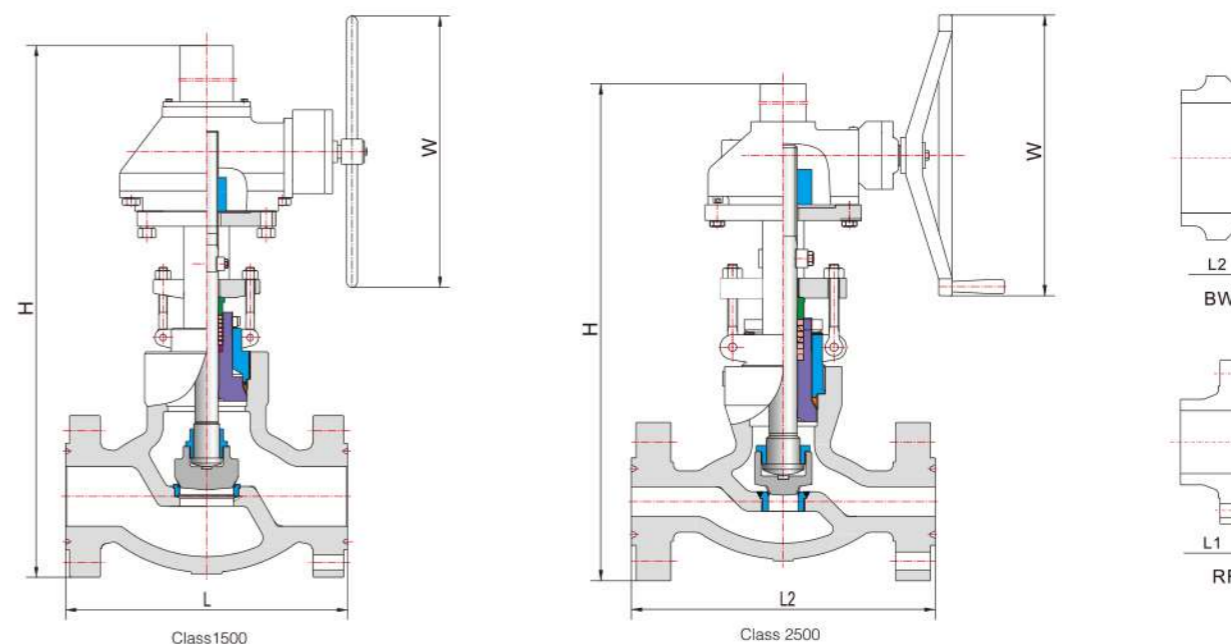

Class 1500

NPS	in	2"	2-1/2"	3"	4"	6"	8"	10"	12"	14"
DN	mm	50	65	80	100	150	200	250	300	350
L(BW)	in	8.5	10	12	16	22	28	34	39	42
	mm	215.9	254	304.8	406.4	558.8	711.2	863.6	990.6	1066.8
L1(RF)	in	14.5	16.5	18.5	21.5	27.8	32.8	39	44.5	49.5
	mm	368.3	419.1	469.9	546.1	704.9	831.9	990.6	1130.3	1257.3
L2(RTJ)	in	14.6	16.6	18.6	21.6	28.1	33.2	39.4	45.1	50.3
	mm	371.3	422.1	472.9	549.1	711.2	841.5	1000	1146	1276.4
W	in	14	14	20	22	24	24	32	39.4	39.4
	mm	355.6	355.6	508	540*	610*	610*	810*	1000*	1000*
H	in	24.4	25.2	32.9	33.7	48.4	70.9	78.78	91	106
	mm	619.7	640	835.6	855.9	1229	1800	2001	2311.4	2692.4
WT(RF)	kg	84	116	143	236	918	1764	2680	3400	4300
WT(BW)	kg	58	62	128	168	781	1502	2280	2830	3600

Class 2500

NPS	in	2"	2-1/2"	3"	4"	6"	8"	10"	12"
DN	mm	50	65	80	100	150	200	250	300
L(BW)	in	11	13	14.5	18	24	30	36	41
	mm	279.4	330.2	368.3	457.2	609.6	762	914.4	1041.4
L1(RF)	in	17.8	20	22.8	26.5	36	40.3	50	56
	mm	451	508	578	673	914	1022	1270	1422
L2(RTJ)	in	17.9	20.3	23	26.9	36.5	40.9	50.9	56.9
	mm	454	514	584	683	927	1038	1292	1445
W	in	16	20	22	24	24	24	39.38	39.38
	mm	400	500	560	610*	610*	610*	1000*	1000*
H	in	24.3	30.7	31.5	51.2	53.9	85	100	106
	mm	617.2	779.8	800.1	1300.5	1369.1	2159	2540	2692.4
WT(RF)	kg	105	163	221	525	1313	2520	3300	4200
WT(BW)	kg	74	116	147	368	973	2100	2500	3300

* Gear Operator

SCPS Series

SuYan SCPS series pressure seal swing check valve are manufactured in accordance with BS1868, ASME B16.34 specification and tested to API 598, and this series valves are of API 591 certified, and TA Luft Certified. To ensure casting integrity, all pressure contain casting are from SuYan own foundry.

Flanged Ends / Butt Welding Ends Pressure Seal Bonnet OS&Y

End to end dimensions and wall thickness conform to ANSI and API specification; Lift check valve also available, data will be supplied upon request; Hard facing seat design; Optional by pass design; Optional double packing with lantern ring; Vacuum PWHT applied for Cr-Mo pup piece welding.



Part	Standard	Stainless Steel	Low Temperature	High Temperature	Sour Service
Body	ASTM A216 WCB	ASTM A351 CF8M	ASTM A352 LCC	ASTM A217 WC9	ASTM A216 WCB
Seat Ring	ASTM A105N+STL.6	ASTM A182 F316	ASTM A350 LF2+STL.6	ASTM A182 F22+STL.6	ASTM A105N+STL.6
Disc	ASTM A216 WCB+Cr13	ASTM A351 CF8M	ASTM A352 LCC+Cr13	ASTM A217 WC9+Cr13	ASTM A216 WCB+Cr13
Hinge	ASTM A216 WCB	ASTM A351 CF8M	ASTM A352 LCC	ASTM A217 WC9	ASTM A216 WCB
Washer	Stainless Steel/Graphite	Stainless Steel/Graphite	Stainless Steel/Graphite	Stainless Steel/Graphite	Stainless Steel/Graphite
Pin	ASTM A182 F6a	ASTM A276 316	ASTM A276 304	ASTM A276 304	ASTM A276 410(NACE)
Disc Nut	ASTM A276 410	ASTM A276 316	ASTM A276 304	ASTM A276 304	ASTM A276 410(NACE)
Lever Set Ring	ASTM A276 410	ASTM A182 F316	ASTM A182 F304	ASTM A182 F304	ASTM A182 F6a(NACE)
Hing Pin	ASTM A182 F6a	ASTM A182 F316	ASTM A182 F304	ASTM A182 F304	ASTM A182 F6a(NACE)
Plate	ASTM A276 410	ASTM A182 F316	ASTM A182 F304	ASTM A182 F304	ASTM A182 F6a(NACE)
Cover	ASTM A105N	ASTM A182 F316	ASTM A350 LF2	ASTM A182 F22	ASTM A105N
*Sealing Ring	SS304 + Graphite	SS316 + Graphite	SS304 + Graphite	SS304 + Graphite	SS304 + Graphite
Spacer Ring	ASTM A276 410	ASTM A182 F316	ASTM A182 F304	ASTM A182 F304	ASTM A276 420(NACE)
Bonnet Nut	ASTM A194 2H	ASTM A194 8	ASTM A194 7	ASTM A194 4	ASTM A194 2HM
Bolt	ASTM A193 B7	ASTM A193 B8	ASTM A320 L7	ASTM A193 B16	ASTM A193 B7M

* Sealing Ring: 4" and below 4" is SS + Graphite
above 4" is SS

CAST STEEL

SCPS SERIES PRESSURE SEAL CHECK VALVE

600LB 900LB

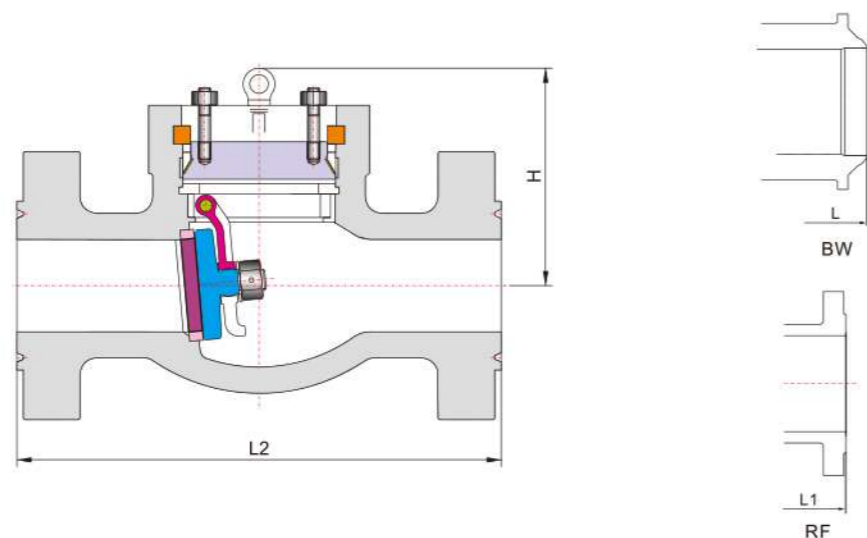

Class 600

NPS	in	2"	2-1/2"	3"	4"	5"	6"	8"	10"	12"	14"	16"	18"	20"	24"	26"	28"	30"
DN	mm	50	65	80	100	125	150	200	250	300	350	400	450	500	600	650	700	750
L(BW)	in	7	8.5	10	12	15	18	23	28	32	/	/	/	/	/	/	/	/
	mm	177.8	215.9	254	304.8	381	457.2	584.2	711.2	812.8	/	/	/	/	/	/	/	/
L1(RF)	in	11.5	13	14	17	20	22	26	31	33	35	39	43	47	55	57	63	65
	mm	292.1	330.2	355.6	431.8	508	558.8	660.4	787.4	838.2	889	990.6	1092.2	1193.8	1397	1447.8	1600.2	1651
L2(RTJ)	in	11.6	13.1	14.1	17.1	20.1	22.1	26.1	31.1	33.1	35.1	39.1	43.1	47.3	55.4	57.5	63.5	65.5
	mm	295.1	333.2	358.6	434.8	511	561.8	663.4	790.4	841.2	892	993.6	1095.5	1200.2	1406.7	1460.5	1612.9	1663.7
H	in	9.5	10.4	10.6	12.5	15.7	15.7	23.1	23.9	27.4	28.7	28.8	29.5	32.3	37.4	39.4	43.3	47.3
	mm	241.3	264.2	269.2	317.5	398.8	398.8	586.7	607.1	696	729	730.3	749.3	819.2	949.5	1000.3	1098.6	1200.2
WT(RF)	kg	27	35	45	85	135	190	350	500	670	880	1150	1480	1880	2600	3100	3500	4000
WT(BW)	kg	18	25	32	55	85	130	260	370	490	660	850	1100	1490	2040	2500	2800	3150

Class 900

NPS	in	2"	2-1/2"	3"	4"	6"	8"	10"	12"	14"	16"	18"	20"	24"	26"	28"	30"
DN	mm	50	65	80	100	150	200	250	300	350	400	50	500	600	650	700	750
L(BW)	in	8.5	10	12	14	20	26	31	36	39	43	48	52	61	63	67	71
	mm	215.9	254	304.8	355.6	508	660.4	787.4	914.4	990.6	1092.2	1219.2	1320.8	1549.4	1600.2	1701.8	1803.4
L1(RF)	in	14.5	16.5	15	18	24	29	33	38	40.5	44.5	48	52	61	65	69	73
	mm	368.3	419.1	381	457.2	609.6	736.6	838.2	965.2	1028.7	1130.3	1219.2	1320.8	1549.4	1651	1752.6	1854.2
L2(RTJ)	in	14.6	16.6	15.1	18.1	24.1	29.1	33.1	38.1	40.9	44.9	48.5	52.5	61.8	65.9	69.9	73.9
	mm	370.8	421.6	383.5	459.7	612.1	739.1	840.7	967.7	1038.9	1140.5	1231.9	1333.5	1569.7	1673.9	1775.5	1877.1
H	in	9.5	10.4	10.6	12.5	15.7	23.1	23.9	27.4	28.7	29.5	33.5	34	37.8	39.4	42.3	55.1
	mm	241.3	264.2	269.2	317.5	398.8	586.7	607.1	696	729	749.3	850.9	863.6	958.9	1000.3	1073.2	1400.3
WT(RF)	kg	42	55	58	110	242	599	893	1365	1628	1733	2300	3000	4100	4600	5200	6000
WT(BW)	kg	21	32	34	68	168	462	725	1071	1281	1418	1850	2400	2900	3600	4000	4600

CAST STEEL

SCPS SERIES PRESSURE SEAL CHECK VALVE

1500LB 2500LB

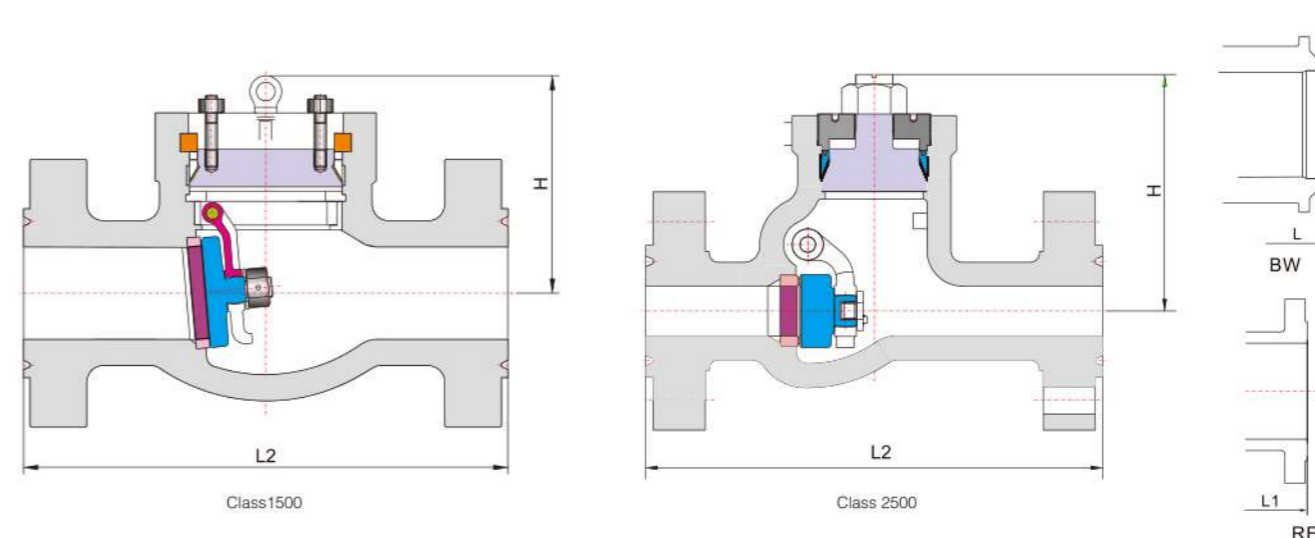

Class1500

NPS	in	2"	2-1/2"	3"	4"	6"	8"	10"	12"	14"	16"	18"	20"	24"
DN	mm	50	65	80	100	150	200	250	300	350	400	450	500	600
L(BW)	in	8.5	10	12	16	22	28	34	39	42	47	53	58	77
	mm	216	254	305	406	559	711	864	991	1067	1194	1346	1473	1956
L1(RF)	in	14.5	16.5	18.5	21.5	27.8	32.8	39	44	49.5	54.4	60.5	65.5	76.5
	mm	368.3	419.1	469.9	546.1	706.12	833.12	990.6	1130.3	1257.3	1381.76	1536.7	1663.7	1943.1
L2(RTJ)	in	14.6	16.6	18.6	21.6	28.1	33.2	39.4	45.1	50.3	55.3	61.4	66.4	77.6
	mm	371	422	473	549	711	842	1000	1146	1276	1407	1559	1686	1972
H	in	9.5	10.4	10.8	12.5	16.6	18.9	23.3	25.4	28	29.5	34.63	37.38	43.25
	mm	241.3	264.2	274.3	317.5	421.6	480.1	591.8	645.7	711.2	749.3	879.6	949.5	1098.6
WT(RF)	kg	42	58	105	147	360	641	1103	1628	2205	2730	3300	4200	6000
WT(BW)	kg	21	34	42	74	233	504	777	1155	1481	1680	2100	2600	3500

Class2500

NPS	in	2"	2-1/2"	3"	4"	6"	8"	10"	12"	14"	16"	18"	20"	24"
DN	mm	50	65	80	100	150	200	250	300	350	400	50	500	600
L(BW)	in	11	13	14.5	18	24	30	36	41	44	49	55	61	68
	mm	279.4	330.2	368.3	457.2	609.6	762	914.4	1041.4	1117.6	1244.6	1397	1549.4	1727.2
L1(RF)	in	17.8	20	22.8	26.5	36	40.3	50	56	/	/	/	/	/
	mm	451	508	578	673	914	1022	1270	1422	/	/	/	/	/
L2(RTJ)	in	17.9	20.3	23	26.9	36.5	40.9	50.9	56.9	/	/	/	/	/
	mm	454	514	584	683	927	1038	1292	1444	/	/	/	/	/
H	in	9.6	10.4	10.6	12.5	17.8	22	22.7	25.8	33.9	35.4	39.4	45.3	55.1
	mm	243.8	264.2	269.2	317.5	452.1	558.8	576.6	655.3	860.6	898.7	1000.3	1149.4	1400.3
WT(RF)	kg	89	124	163	299	588	1071	1676	2772	/	/	/	/	/
WT(BW)	kg	53	74	89	142	286	598	783	1512	2450	3200	4050	5000	7200

GATE VALVE ETORQUE & THRUST



SUYAN VALVE

GATE VALVE TORQUE & THRUST



SUYAN VALVE

Class	Item	Valve Size											Valve Size											
		2"	2.5"	3"	4"	5"	6"	8"	10"	12"	14"	16"	18"	20"	24"	28"	30"	32"	36"	40"	42"	48"	60"	
150	Stem Dia. inch (Thread Area)	3/4"	3/4"	7/8"	1"	1-1/8"	1-1/8"	1-1/4"	1-3/8"	1-1/2"	1-5/8"		1-3/4"	1-7/8"	2"	2-1/4"	2-1/2"	2-3/4"	2-3/4"	3"	3-1/4"	3-3/8"	3-3/4"	4.5"
	No of Threads per inch	6	6	6	5	5	5	5	4	4	4		4	4	4	3	3	3	3	2	2	2	2	2
	Pitch inch	0.1667	0.16667	0.1667	0.2	0.2	0.2	0.2	0.25	0.25	0.25		0.25	0.25	0.25	0.3333	0.3333	0.3333	0.3333	0.5	0.5	0.5	0.5	0.5
	Stem Dia. mm (Packing Area)	19.1	19.1	22.3	25.4	28.6	28.6	31.8	35	38.1	41.3		44.5	47.7	50.8	57.2	63.5	69.9	69.9	76.2	82.6	85.7	95.3	114.3
	Lead inch (D.H.)			0.3333	0.4	0.4	0.4	0.4	0.5	0.5	0.5		0.5	0.5	0.5	0.6667	0.6667	0.6667	0.6667	1	1	1	1	1
	Gear Type					EA-00	EA-00	EA-00	EA-00	EA-00	EA-0		EA-0	EA-0	EA-1	EA-1	EA-2	EA-2	EA-2	EA-3	EA-3	EA-3	EA-3	SZX-4A
	Inside Dia. mm Stuffing Box	32.5	32.5	35.7	38.9	45.2	45.2	48.4	51.6	57.9	61.1		64.3	67.5	73.8	83.3	89.7	96	96	105.6	111.9	118.6	134.1	152
	ISO Flange					F14	F14	F14	F14	F14	F16		F16	F16	F25	F25	F30	F30	F30	F35	F35	F35	F35	F40
	Travel mm	67	81	94	116	148	177	224	276	329	363		415	461	516	620	730	780	830	910	1040	1070	1234	1523
	No of Truns	16	19	22	23	29	35	44	43	52	57		65	73	81	73	86	92	98	72	82	84	97	120
	Torque N.M	15.5	17.3	21.6	38	50.1	60.5	93.6	145.2	209.7	258		355.4	471.4	630	1016.4	1517	1889.3	2040.2	2931	4029.9	4328.5	6220.7	11152.7
Thrust KN	6.2	6.9	7.7	11.5	13.9	16.8	24	33	44.6	51.6		65.8	82.7	105	147.3	199.6	203.4	248.8	311.8	399	416.2	550.5	844.9	
300	Stem Dia. inch (Thread Area)	3/4"	3/4"	7/8"	1"	1-1/8"	1-1/4"	1-3/8"	1-1/2"	1-5/8"	1-3/4"		1-7/8"	2"	2-1/8"	2-1/2"	2-3/4"	3-1/4"						
	No of Threads per inch	6	6	6	5	5	5	4	4	4	4		4	4	3	3	3	2						
	Pitch inch	0.1667	0.16667	0.1667	0.2	0.2	0.2	0.25	0.25	0.25	0.25		0.25	0.25	0.3333	0.3333	0.3333	0.5						
	Stem Dia. mm (Packing Area)	19.1	19.1	22.3	25.4	28.6	31.8	35	38.1	41.3	44.5		47.7	50.8	54	63.5	69.9	82.6						
	Lead inch (D.H.)			0.3333	0.4	0.4	0.4	0.5	0.5	0.5	0.5		0.5	0.5	0.6667	0.6667	0.6667	1						
	Gear Type					EA-00	EA-00	EA-00	EA-00	EA-00	EA-0		EA-0	EA-1	EA-1	EA-2	EA-3	EA-3						
	Inside Dia. mm Stuffing Box	32.5	32.5	35.7	38.9	45.2	48.4	51.6	57.9	61.1	64.3		67.5	73.8	77	89.7	96	111.9						
	ISO Flange					F14	F14	F14	F14	F14	F16		F16	F25	F25	F30	F35	F35						
	Travel mm	70	80	95	118	143	170	220	276	320	350		415	458	507	610	735	770						
	No of Truns	17	19	22	23	28	33	35	43	50	55		65	72	60	72	87	61						
	Torque N.M	21	25.8	33.9	62.7	90.4	127.6	226.6	342.7	513.5	678.3		929.1	1231.8	1728.6	2738.3	4099.2	5720.7						
Thrust KN	8.4	10.3	12.1	19	25.1	32.7	51.5	72.9	102.7	125.6		163	205.3	261.9	360.3	499.9	566.4							
600	Stem Dia. inch (Thread Area)	3/4"	7/8"	1"	1-1/8"	1-1/2"	1-5/8"	1-7/8"	2"	2-1/4"		2-3/8"	2-1/2"	2-3/4"	3"									
	No of Threads per inch	6	6	5	5	4	4	4	4	3		3	3	3	2									
	Pitch inch	0.1667	0.16667	0.2	0.2	0.25	0.25	0.25	0.25	0.3333		0.3333	0.3333	0.3333	0.5									
	Stem Dia. mm (Packing Area)	19.1	22.3	25.4	28.6	38.1	41.3	47.7	50.8	57.2		60.3	63.5	69.9	76.2									
	Lead inch (D.H.)			0.4	0.4	0.5	0.5	0.5	0.5	0.6667		0.6667	0.6667	0.6667	1									
	Gear Type					EA-0	EA-0	EA-0	EA-1	EA-2		EA-2	EA-2	EA-2	EA-3									
	Inside Dia. mm Stuffing Box	32.5	35.7	38.9	45.2	N.A.	57.9	61.1	67.5	73.8	83.3		86.5	89.7	96	105.6								
	ISO Flange					F16	F16	F16	F25	F30		F30	F30	F30	F35									
	Travel mm	71	80	98	111	174	227	274	332	363		410	440	505	595									
	No of Truns	17	19	19	22	27	36	43	52	43		48	52	60	47									
	Torque N.M	34.5	55.2	85.2	128.6	319.2	542.5	903.5	1320.6	1809.9		2451.6	3107.7	4105	6557.5									
Thrust KN	13.8	19.7	25.8	35.7	67.9	108.5	158.5	220.1	262.3		340.5	408.9	500.6	697.6										
900	Stem Dia. inch (Thread Area)	1"		1-1/8"	1-1/4"	1-5/8"	1-7/8"	2-1/8"	2-1/4"	2-3/8"		2-1/2"	2-3/4"	3"	4"									
	No of Threads per inch	5		5	5	4	4	3	3	3		3	3	2	2									
	Pitch inch	0.2		0.2	0.2	0.25	0.25	0.3333	0.3333	0.3333		0.3333	0.3333	0.5	0.5									
	Stem Dia. mm (Packing Area)	25.4		28.6	31.8	41.3	47.7	54	57.2	60.3		63.5	69.9	76.2	102.5									
	Lead inch (D.H.)			0.4	0.4	0.5	0.5	0.6667	0.6667	0.6667		0.6667	0.6667	1	1									
	Gear Type					EA-1	EA-1	EA-2	EA-2			EA-2	EA-2	EA-3	EA-3									
	Inside Dia. mm Stuffing Box	38.9	N.A.	45.2	48.4	N.A.	61.1	67.5	77	83.3	86.5		89.7	96	111.9	105.6								
	ISO Flange						F25	F25	F30	F30		F30	F30	F35	F35									
	Travel mm	68		97	116		164	217	265	300	335		383	434	485	568								
	No of Truns	13		19	23		26	34	31	35	40		45	51	38	45								
	Torque N.M	74		122.8	198.6		493.5	853.9	1516.1	2069.4	2640.3		3415.5	4608.4	7093.3	12198								
Thrust KN	22.4		34.1	50.9		98.7	149.8	229.7	299.9	366.7		449.4	562	702.3	1008.1									
1500	Stem Dia. inch (Thread Area)	1"		1-1/4"	1-3/8"	1-3/4"	2-1/8"	2-1/2"	2-3/4"															
	No of Threads per inch	5		5	4	4	3	3	3															
	Pitch inch	0.2		0.2	0.25	0.25	0.3333	0.3333	0.3333															
	Stem Dia. mm (Packing Area)	25.4		31.8	34.9	44.5	54	63.5	69.9															
	Lead inch (D.H.)			0.4	0.5	0.5	0.6667	0.6667	0.6667															
	Gear Type				EA-00	EA-0	EA-1	EA-2	EA-2															
	Inside Dia. mm Stuffing Box	38.9	N.A.	48.4	51.6	N.A.	64.3	77	89.7	96														
	ISO Flange				F14		F16	F25	F30	F30														
	Travel mm	68		90	114		152	200	250	288														
	No of Truns	13		18	18		24	24	30	34														
	Torque N.M	108.3		218.8	341		789.5	1578.8	2679	3890.9														
Thrust KN	32.8		56.1	77.5		146.2	239.2	352.5	474.5															

GLOBE VALVE TORQUE & THRUST



SUYAN VALVE

MEMO



SUYAN VALVE

Class	Item	Valve Size										
		2"	2.5"	3"	4"	5"	6"	8"	10"	12"	14"	16"
150	Stem Dia. inch (Thread Area)	7/8"	7/8"	1"	1-1/8"	1-1/4"	1-1/4"	1-1/2"	1-5/8"	2-1/8"	2-3/8"	2-1/2"
	No of Threads per inch	5	5	5	5	5	5	4	4	3	3	3
	Pitch inch	0.2	0.2	0.2	0.2	0.2	0.2	0.25	0.25	0.333	0.333	0.333
	Stem Dia. mm (Packing Area)	22.3	22.3	25.4	28.6	31.8	31.8	38.1	41.3	54	60.3	63.5
	Lead inch (D.H.)	0.4	0.4	0.4	0.4	0.4	0.4	0.5	0.5	0.667	0.667	0.666
	Gear Type				EA-00	EA-00	EA-00	EA-0	EA-0	EA-1	EA-2	EA-2-2A
	Inside Dia. mm Stuffing Box	35.7	35.7	38.9	45.2	48.4	48.4	57.9	61.1	77	86.5	89.7
	ISO Flange				F14	F14	F14	F16	F16	F25	F30	F30
	Travel mm	27	29	33	33	52	43	68	66	90	120	121
	No of Truns	5	6	6	6	10	8	11	10	11	14	14
	Torque N.M	28.5	37.7	57.1	91.1	138.1	177.9	358.7	497	1029	1257.9	1906.1
	Thrust KN	9.8	13	17.3	25.3	35.4	45.6	76.3	99.4	155.9	174.7	250.8
	300	Stem Dia. inch (Thread Area)	7/8"	7/8"	1"	1-1/4"	1-1/4"	1-1/2"	1-7/8"	2-1/8"	2-3/8"	2-1/2"
No of Threads per inch		5	5	5	5	5	4	4	3	3	3	3
Pitch inch		0.2	0.2	0.2	0.2	0.2	0.25	0.25	0.333	0.333	0.333	0.333
Stem Dia. mm (Packing Area)		22.3	22.3	25.4	31.8	31.8	38.1	47.7	54	60.3	63.5	69.9
Lead inch (D.H.)		0.4	0.4	0.4	0.4	0.4	0.5	0.5	0.667	0.667	0.667	0.667
Gear Type					EA-00	EA-00	EA-0	EA-1	EA-2	EA-2	EA-3	EA-3
Inside Dia. mm Stuffing Box		35.7	35.7	38.9	48.4	48.4	57.9	67.5	77	86.5	89.7	96
ISO Flange					F14	F14	F16	F25	F30	F30	F35	F35
Travel mm		28	44	30	50	46	46	58	83	123	112	124
No of Truns		6	9	6	10	9	7	9	10	15	13	15
Torque N.M		50.8	69.6	112.9	214.2	317.1	507.2	989	1664.6	2952	3325.8	4995.5
Thrust KN		17.5	24	34.2	54.9	81.3	107.9	173.5	252.2	410	437.6	609.2
600		Stem Dia. inch (Thread Area)	7/8"	1-1/8"	1-1/8"	1-3/4"		2-1/8"	2-3/8"	2-3/8"	2-3/4"	3"
	No of Threads per inch	5	5	5	4		3	3	3	3	2	
	Pitch inch	0.2	0.2	0.2	0.25		0.333	0.333	0.333	0.333	0.5	
	Stem Dia. mm (Packing Area)	22.3	28.6	28.6	44.5		54	60.3	60.3	69.9	76.2	
	Lead inch (D.H.)	0.4	0.4	0.4	0.5		0.667	0.667	0.667	0.667	1	
	Gear Type		EA-00	EA-00	EA-0		EA-1	EA-2-2A	EA-2-2A	EA-3	EA-3	
	Inside Dia. mm Stuffing Box	35.7	45.2	45.2	64.3	NA	77	86.5	86.5	96	105.6	
	ISO Flange		F14	F14	F16		F25	F30	F30	F35	F35	
	Travel mm	53	46	42	77		82	63	76	130	115	
	No of Truns	10	9	8	12		10	7	9	15	9	
	Torque N.M	101.8	200.9	257.8	681.5		1580.1	3119.1	3878.7	5714.6	8465.7	
	Thrust KN	35.1	55.8	71.6	126.2		239.4	433.2	538.7	696.9	900.6	
	900	Stem Dia. inch (Thread Area)	1-1/4"	1-1/4"	1-3/4"	1-5/8"		2-1/4"	2-1/2"	2-3/4"	3-1/4"	
No of Threads per inch		5	5	4	4		3	3	3	2		
Pitch inch		0.2	0.2	0.25	0.25		0.333	0.333	0.333	0.5		
Stem Dia. mm (Packing Area)		31.8	31.8	44.5	41.3		57.2	63.5	69.9	82.6		
Lead inch (D.H.)		0.4	0.4	0.5	0.5		0.667	0.667	0.667	1		
Gear Type					EA-0		EA-2	EA-2-2A	EA-2-2A	EA-3		
Inside Dia. mm Stuffing Box		48.4	48.4	64.3	61.1	NA	83.3	89.7	96	111.9		
ISO Flange					F16		F30	F30	F30	F35		
Travel mm		20	27	27	49		54	82	94	96		
No of Truns		4	5	4	8		6	10	11	8		
Torque N.M		209.5	232.9	598.4	787.5		2470.2	4407.3	6011.5	10741.4		
Thrust KN		53.7	59.7	110.8	157.5		358	579.9	733.1	1063.5		
1500		Stem Dia. inch (Thread Area)	1-1/4"	1-1/4"	1-3/4"	2-1/8"		2-3/8"	2-3/4"			
	No of Threads per inch	5	5	4	3		3	3				
	Pitch inch	0.2	0.2	0.25	0.333		0.333	0.333				
	Stem Dia. mm (Packing Area)	31.8	31.8	44.5	54		60.3	69.9				
	Lead inch (D.H.)	0.4	0.4	0.5	0.667		0.667	0.667				
	Gear Type				EA-1		EA-2-2A	EA-3				
	Inside Dia. mm Stuffing Box	48.4	48.4	64.3	77	NA	86.5	96				
	ISO Flange				F25		F30	F35				
	Travel mm	18	27	74	44		52	78				
	No of Truns	4	5	12	5		6	9				
	Torque N.M	331.2	370.2	914.8	1654		3335.1	6287.8				
	Thrust KN	84.9	94.9	169.4	250.6		463.2	766.8				

Note:

- 1.S.H.=Single Head Suitable for Electrical Actuator operated.
- 2.D.H.=Double Head Suitable for manual operated.
- 3.Number of Turns based on S.H.

- 4.Torque or thrust based on normal pressure and temperature.
- 5.Torque or thrust based on S.H.
- 6.The Safety factor 1.25 -1.5 is recommended for actuator sizing.